

Mod. Data DESCRIZIONE Dis. Contr. Approv.

Musserra

·

·

·

·

·

·

·

·

·

·

·

·

·

·



- ➔ FLUSSO ARIA AL CONDENSATORE
CONDENSER AIR FLOW
- ENTRATA ACQUA DN80 - 3" - GAS M.
WATER INLET DN80 - 3" - BSP M.
- ▷ USCITA ACQUA DN80 - 3" - GAS M.
WATER OUTLET DN80 - 3" - BSP M.

- (kg) PESO DI SPEDIZIONE Kg 2320~
SHIPPING WEIGHT Kg 2320~
- (kg) PESO IN OPERA Kg 3320~
OPERATING WEIGHT Kg 3320~

- ① VENTILATORE ASSIALE
AXIAL FAN
- ② QUADRO ELETTRICO
ELECTRICAL BOARD
- ③ COMPRESSORE SEMIHERMETICO
SEMI-HERMETIC COMPRESSOR
- ④ BATTERIA CONDENSANTE
AIRCOOLED CONDENSER
- ⑤ EVAPORATORE / SERBATOIO
EVAPORATOR / TANK
- ⑥ POMPA
PUMP
- ⑦ SCARICO CONDENSATA
CONDENSATE DISCHARGE
- ⑧ VASO ESPANSIONE
EXPANSION TANK

- ⑨ SCARICO ACQUA DN15-1/2" GAS M.
WATER DISCHARGE DN15-1/2" BSP M.
- ⑩ ALIMENTAZIONE ELETTRICA
POWER SUPPLY

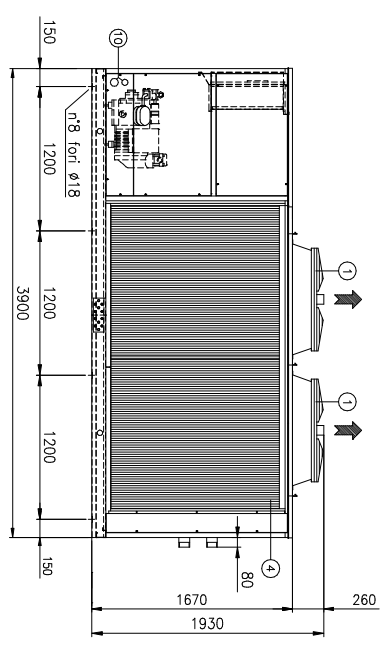
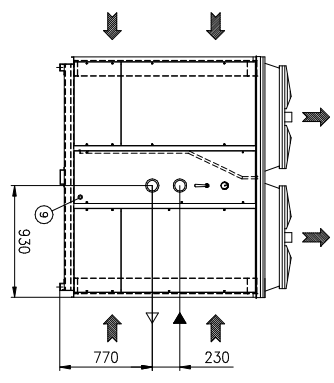
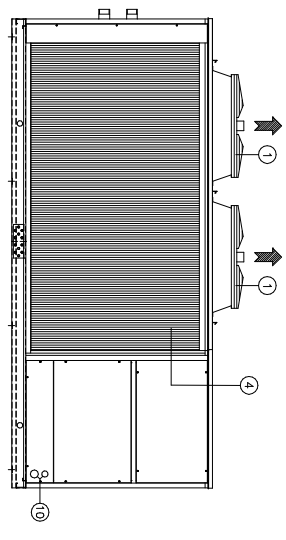

VISTA LATERALE
SIDE VIEW

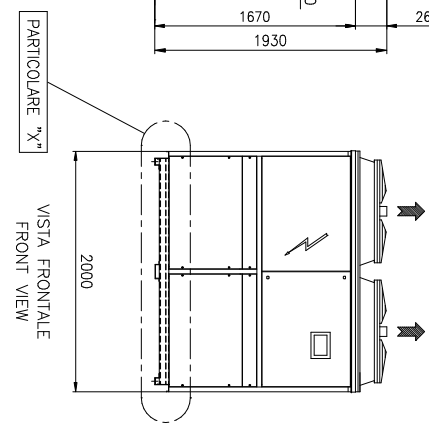

VISTA FRONTALE
FRONT VIEW

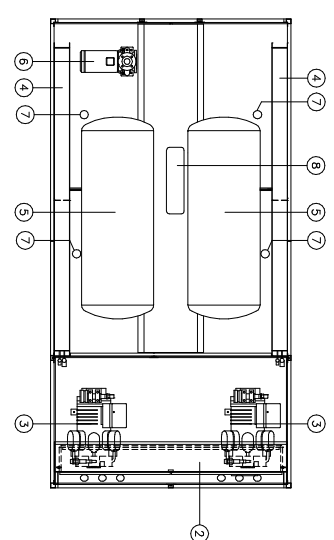

VISTA IN SEZIONE
CROSS SECTION

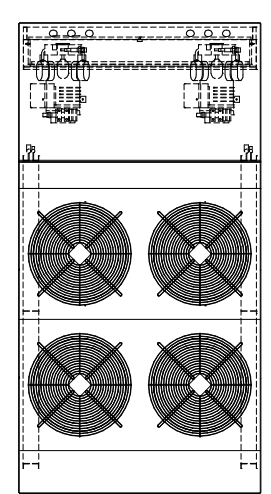

VISTA SUPERIORE
TOP VIEW

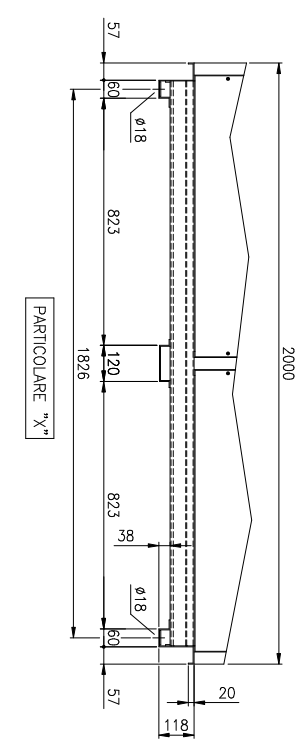

PARTICOLARE "X"

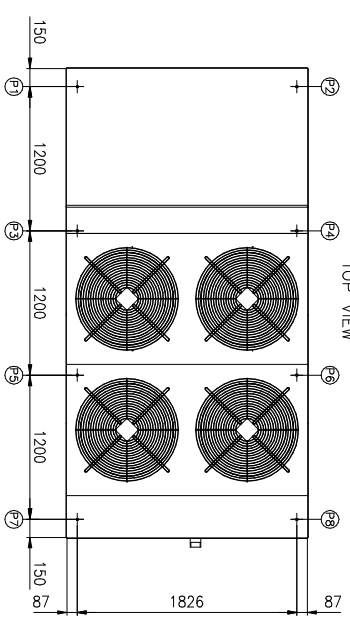

VISTA SUPERIORE
TOP VIEW

DISTRIBUZIONE PESI Kg/WEIGHT DISTRIBUTION Kg

FORI/HOLES	(P1)	(P2)	(P3)	(P4)	(P5)	(P6)	(P7)	(P8)
Ø18								
ATTIVABRANTI SPRINGS								

EUROKLIMAT S.p.A. Via Liguria, 8 - 27010 - Siano (Pavia)

Disegno n° : 15501260/010/A

Valido per: .

Lo EUROKLIMAT si riserva la proprietà del presente disegno che non può essere riprodotto né trasmesso a terzi senza espresso autorizzazione