

Dis.	Contr.	Approv.
Musserra		
Musserra		
Musserra		

Mod.	Data	DESCRIZIONE
A	13/04/11	Emissione
B	23/06/12	Modificato pos. attacchi
C	16/07/12	Aggiunto vaso aperto opzionale
D	12/10/15	Attacchi femmina

- ➔ FLUSSO ARIA AL CONDENSATORE
CONDENSER AIR FLOW
- ▲ ENTRATA ACQUA DN80 - 3" - GAS F.
WATER INLET DN80 - 3" - BSP F.
- ▷ USCITA ACQUA DN80 - 3" - GAS F.
WATER OUTLET DN80 - 3" - BSP F.
- Ⓢ PESO DI SPEDIZIONE Kg 2170~
SHIPPING WEIGHT Kg 2170~
- Ⓢ PESO IN OPERA Kg 3110~
OPERATING WEIGHT Kg 3110~

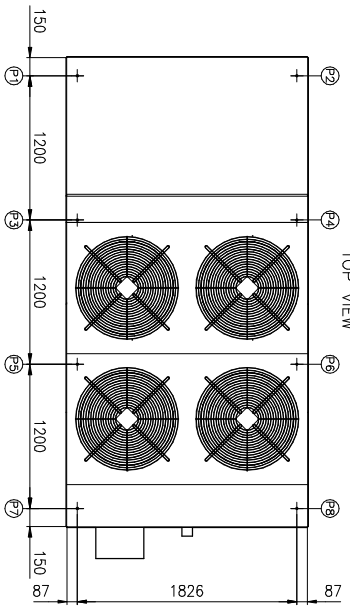
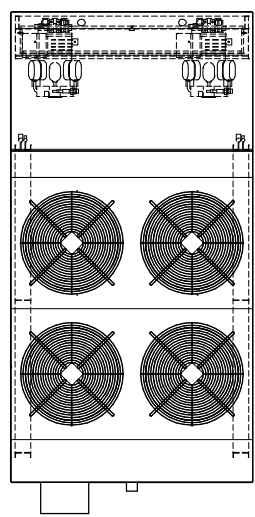
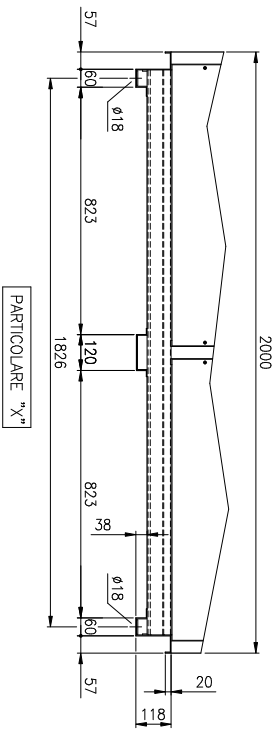
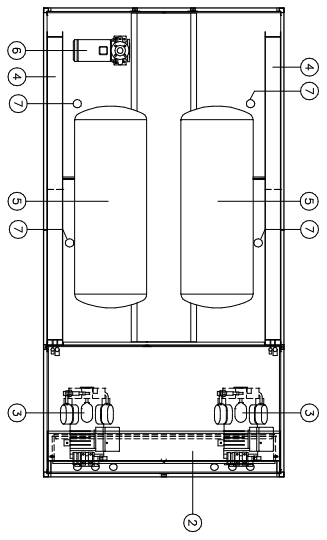
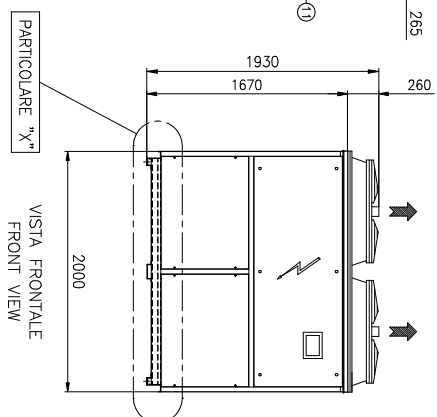
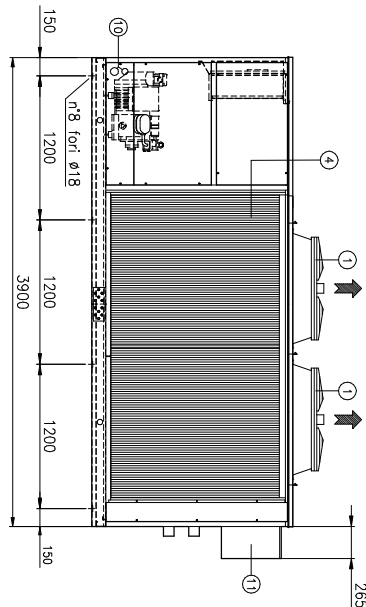
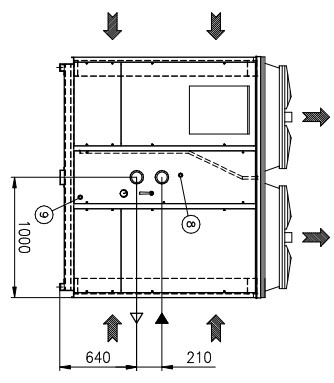
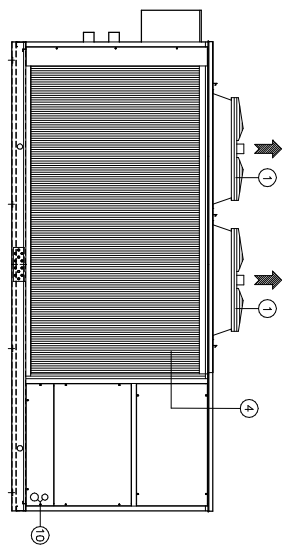

- ① VENTILATORE ASSIALE
AXIAL FAN
- ② QUADRO ELETTRICO
ELECTRICAL BOARD
- ③ COMPRESSORE SEMI-ERMETICO
SEMI-HERMETIC COMPRESSOR
- ④ BATTERIA CONDENSANTE
AIRCOOLED CONDENSER
- ⑤ EVAPORATORE / SEPARATO
EVAPORATOR / TANK
- ⑥ POMPA
PUMP
- ⑦ SCARICO CONDENSA
CONDENSATE DISCHARGE
- ⑧ VALVOLA SFOGO ARIA
AIR PURGE VALVE
- ⑨ SCARICO ACQUA
WATER DISCHARGE
- ⑩ ALIMENTAZIONE ELETTRICA
POWER SUPPLY
- ⑪ VASO ESPANSIONE APERTO (OPZIONALE)
OPEN EXPANTION TANK (OPTIONAL)

DISTRIBUZIONE PESI Kg/WEIGHT DISTRIBUTION Kg								
FORN/HOLES	Ⓟ1	Ⓟ2	Ⓟ3	Ⓟ4	Ⓟ5	Ⓟ6	Ⓟ7	Ⓟ8
ANTIVIBRANTI SPRINGS	267	267	435	435	706	710	135	155

EUROKLIMAT S.p.A. Via Liguria, 8 - 27010 - Siano (Pavia)
Dimensione EKE-IPF 802

Scala: / Disegno n° : 15501250/010/D
Valido per: .

Lo EUROKLIMAT si riserva la proprietà del presente disegno che non può essere riprodotto né trasmesso a terzi senza espresso autorizzazione