

# New, Innovative Advanced Compressed Air Desiccant Dryers with High Levels of Performance and Reliability, Backed Up with a 5 Year Warranty

Author: Colin Billet, Chief Executive of nano-porous systems limited.  
 Former Chief Executive of the domnick hunter group PLC  
 Past President of the British Compressed Air Society, now an honorary member  
 Past activities with Pneurop and ISO committees led to the introduction of ISO 8573.1, Quality Classes for Compressed Air  
 Author of many technical papers and patents

## Background

This paper discusses common issues affecting the reliability of compressed air desiccant dryers leading to loss of performance. The new nano dryers have addressed these issues through innovative design. (Patents pending)

High efficiency compressed air dryers are used in critical applications where humidity levels (pressure dew point) are specified to ISO 8573.1 Quality Classes. Typical applications are for use in dental, medical, laboratory, automotive, electronics, telecommunications, pharmaceutical, laser cutting etc. etc.

Desiccant air dryers are selected when the air purity is critical for the application. The design of such products must therefore ensure high levels of performance and reliability. The new nano-porous systems limited (nano) dryer has been designed to ensure that high standards of performance and reliability are achieved.

## Compressed air systems

Compressed air contains contaminants such as water, oil and particulate which must be removed before use. ISO8573.1 specifies air quality standards for these contaminants. The new nano dryers will produce air quality levels for humidity classes 1-3. Classifications for oil and particulate will be determined by the filtration specified to meet any of the quality classes for oil and particulate. Humidity is expressed in terms of Pressure Dew Point (pdp). Dew point is 'the temperature at which air is saturated with moisture, or in general the temperature at which gas is saturated with respect to a condensable component'. When the temperature of the air reduces to or below the dewpoint, condensation will occur.

## Desiccant adsorption dryers

Desiccant air dryers are used for high purity applications where pressure dewpoints of -70,-40 and -20°C are required according to ISO8573.1 humidity classes 1, 2 and 3 respectively.

Unique patented nano desiccant cartridge.



Adsorption is a process whereby specific molecules (the adsorbate) adhere to the surface of a highly porous solid (the adsorbent) by electrostatic and molecular forces. The adsorbent has a specific pore structure which will be a combination of larger or macro pores, slightly smaller or mesopores, or very small pores known as micro pores.

The adsorbent is normally made into granules or beads which are used to form packed beds through which the adsorbate is passed and the process of adsorption can take place. The rate of adsorption is affected by several factors which ultimately determine the adsorption isotherm profile and thus the size of the packed bed.

## Principles of operation

Heatless desiccant dryers are the most common due to their simplicity and hence low cost. A heatless twin tower dryer (see figure opposite) operates by removing moisture through adsorption onto a granular desiccant bed from the feed air (typically at 7 barg) as it flows up through a packed bed of desiccant, column A. Column B (having been previously used in drying the inlet air) is at atmospheric pressure and dry purge air from the outlet of column A is fed through a purge valve, expanded to near atmospheric pressure, and flowed in contra flow direction down through column B to effect the regeneration of its granular desiccant bed. When the desiccant in column A becomes saturated with water vapour (usually determined by a simple timer controller) the feed air is switched back to column B, after it has been pressurised, and the cycle continues.

## Reliability designed in

Granular adsorbents are highly efficient but must be handled with care since certain conditions will render them ineffective requiring the material to be replaced. Overloading with water vapour, water aerosol or bulk water will result in loss of performance and probable destruction of the adsorbent.

### Common failure modes in conventional desiccant dryers consist of:

**Excessive water loading** due to inefficient inlet filtration, condensate drain malfunction and condensation occurring within the dryer.

The new nano design has sought to eliminate such failure conditions in two ways:

- A high efficiency water separation stage is located within the dryer to ensure all bulk water and aerosols are removed and essentially only water vapour is presented to the adsorption stage
- Small amounts of water separated during this stage are contained in a quiet zone, preventing re-entrainment into the air flow, prior to being discharged when the drying columns are switched using reliable solenoid valves

**Purge air loss** or reduction is another common problem which results in incomplete regeneration and loss of dew point leading to serious failure if left unchecked. Such problems are caused by purge air control valves becoming blocked or back pressure built up in the exhaust air silencers with desiccant dust. Both conditions lead to reduced volumetric purge air flow which result in incomplete regeneration.

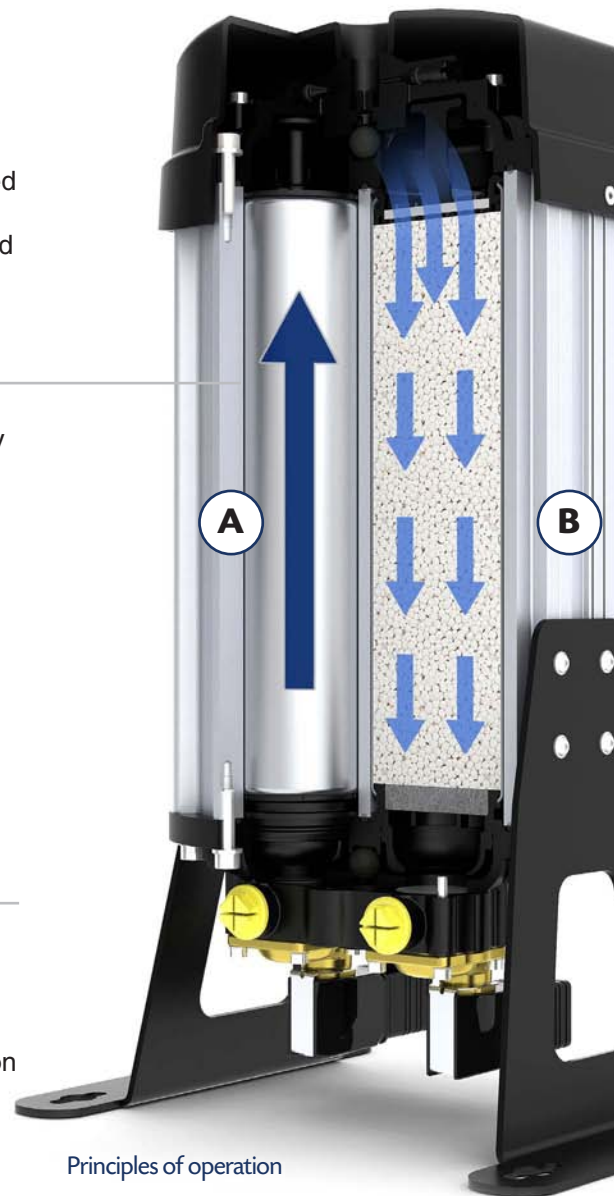

Principles of operation



Quick release outlet connector.



PLC controller with clear text display.

The new nano design addresses such failure conditions in two ways:

- The purge air is pre-filtered - preventing dust build up on the purge air control valves
- The new novel exhaust air silencer has low back pressure and an open structure which prevents pressure build up over time

**Dryer overflow** is common due to excessive demand for air from the dryer.

Where the air flow is limited by the compressor size, reduced pressure causes excessive volumetric flow and higher moisture loadings. This leads to incomplete regeneration and loss of dew point.

Where a desiccant dryer is used for point of use applications and the air is supplied from a compressed air ring main it is often difficult to know the actual air demand and excessive flow can easily occur.

The new nano design has addressed such failure conditions:

- Each dryer is fitted with a volumetric flow limiter to prevent overflow

**Build quality**, while many products are built within an ISO9001 accredited facility mistakes may sometimes occur in assembly.

The nano design has dealt with such problems in 3 ways:

- Every nano dryer is pressure tested and checked for zero leaks
- Every nano dryer is 100% function tested
- Every nano dryer is also 100% tested for dew point performance

**Control and display** is provided by the use of a robust, some would say 'bullet proof' Programmable Logic Controller (PLC).

The nano PLC features:

- Display of hours run, column in use and contact details
- Options include pdp measurement and control and pressure sensing
- Volt free contacts for external alarm warning
- An energy saving feature stops the dryer to save purge air when the compressor is off line
- Power-on light and on/off switch
- Service alarm light and flashing display
- Switch mode power supply for input voltage and frequency world wide
- Connecting cables (3) which means there is no requirement for a qualified electrician
- Pneumatic control option

**Energy saving** is important and the nano range has achieved significant energy savings through the following innovative design features:

- 2 stages of filtration (inlet and outlet) have been integrated into the design eliminating external housings and pipe losses (if oil is present a high efficiency coalescing filter is required)
- Careful management of air flow has resulted in reduced purge air required for regeneration - 15% purge required
- All models have a dew point switching option which typically can save 60% of compressor energy
- Payback with dew point switching for a 15KW compressor system is approximately 12 months for a complete dryer
- If only the cost of the dew point switching option is considered payback is only 3-4 months

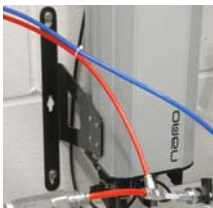

Wall mountable base.



Atmospheric exhaust silencer.

**Serviceability** is important to ensure continued performance.

The unique filtration and adsorption cartridge makes servicing simple:

- 12,000 hours and 5 year service kits
- Replacement cartridges are factory built
- Built in inlet and outlet filters
- No special tools are required
- Handling of loose desiccant/contaminates avoided

Initial installation is made easy by the inclusion of all parts necessary to get started including electrical connection leads and mounting brackets which allow floor or wall mounting.

## Warranty

A 5 year warranty comes as standard with every nano dryer provided that:-

- Operation is in accordance with recommendations
- No unauthorised modification has been made
- Only genuine spares are used at recommended service intervals

## Innovation

The new **nano** dryers have introduced innovative improvements such that significant operational advantages are achieved economically and with reduced pressure losses, saving energy.

- The nano dryers can be supplied as simple modules without controls which enable 'machine builders' to operate the nano dryer with their own controller. This simplifies use by eliminating integration issues between control systems and also significantly reduces cost.
- The novel design of silencers reduce noise levels to <60dB(a).
- Either floor or wall mounting options are available using the standard brackets supplied.
- Typically the reduction in pressure loss results in energy saving that recovers the full purchase cost of the nano dryers within their lifetime.
- The new design is the culmination of innovation and experience which is believed to have resulted in the most reliable product of its type available in the market. So much so that a 5 year warranty comes as standard.
- The new nano design comes ready to use, everything needed is in the box and suitable for use with power supplies globally. 100-250VAC, 50 and 60 Hz.

