

Technical Catalogue

EKE



Scroll Air-Cooled Liquid Chillers for Process

Nominal cooling capacity: 12-391 kW | 50 Hz



EUROKLIMAT®
Cooling System Solutions

EKE Solutions



Market demands



Euroklimat's responses

Elevated reliability

Quality assembly and components

Easy maintenance

Simplified design

Systems able to offer an advantage in terms of productivity

Machines dedicated to the specific application

Index

Product range				4
Process Cooling application				6
Process Cooling references				9
How it is made				10
The Process Cooling Chiller				12
No Frost Evaporator - Euroklimat patent				14
EKE	21	↔	201	16
EKE	252	↔	702	18
EKE	804	↔	1404	20
Performance tables by model				22
Performance tables by temperature conditions				26
Standard Electronic Controller				30
Remote monitoring services tERA				31
Advanced Electronic Controller				32
Sound level				34
How to select				35
Standard equipment and Accessories				36
Electrical data				42
Customer interface				43
Dimensions and Operating spaces				44
Standard and optional packaging				53
P & ID				54
WebService ²				57
Our plants and quality management				58

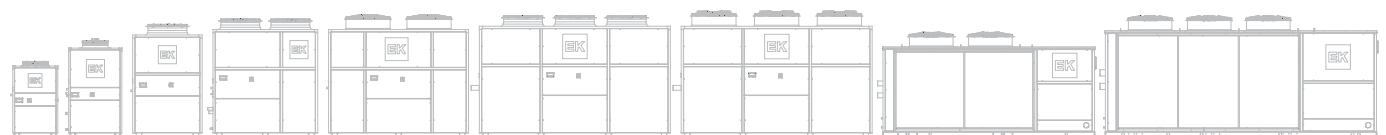

EKE

21

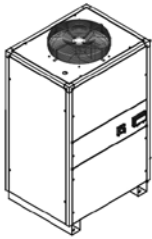

31 ↔ 51

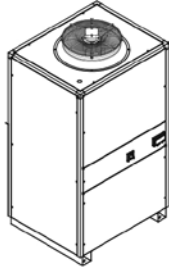

81 ↔ 151

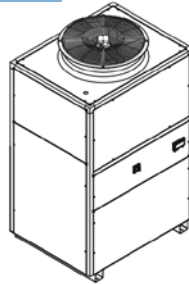

201 ↔ 252



302 ↔ 402



Cooling Capacity ⁽¹⁾

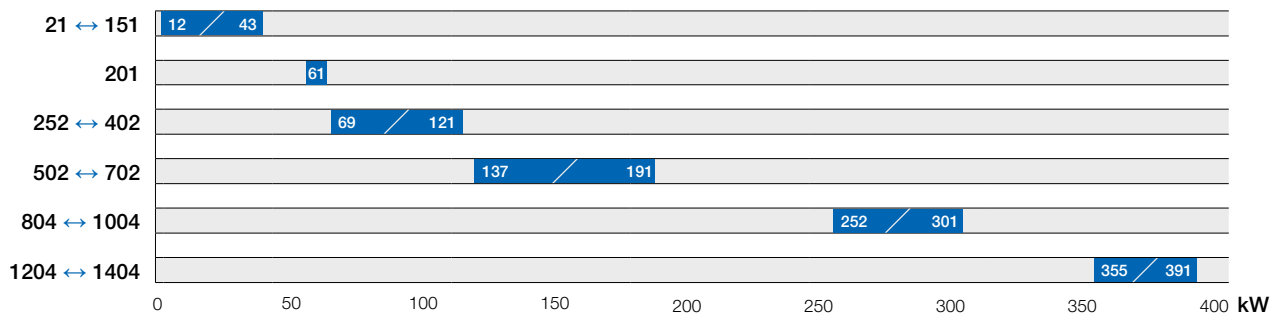

Reference conditions:

- ⁽¹⁾ Condenser air intake temperature = 25°C
 Evaporator water temperature IN/OUT = 20/15°C
 Fluid: water - Condensing coil: Cu/Al



	N. of refrigerant circuits	Compressors Quantity	Fans quantity	Evaporator type
21 ↔ 151	1			
201	1			
252 ↔ 402	1			
502 ↔ 702	2			
804 ↔ 1004	2			
1204 ↔ 1404	2			

Icons legend



"Ecodesign" compliance for process application (SEPR)



Refrigerant R410A | GWP=2.088



Scroll compressor



Axial fan



Braze plate heat exchanger



No Frost evaporator

Product range

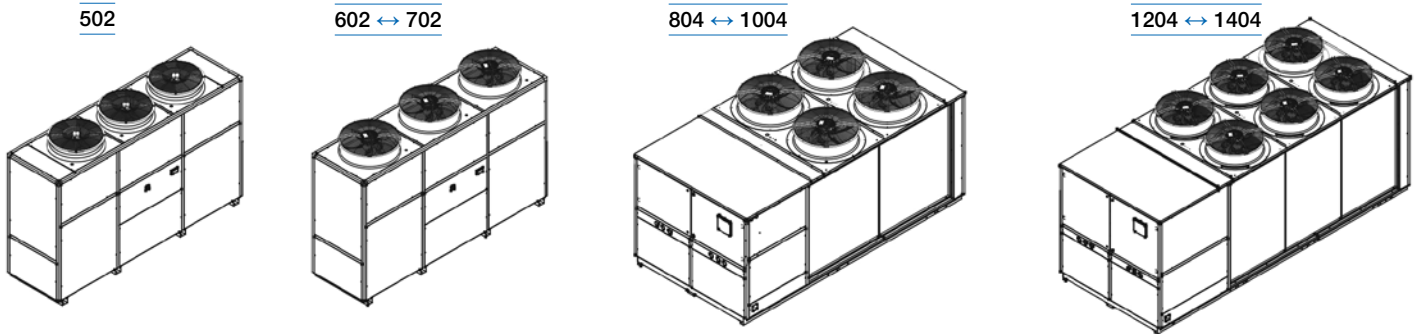

Nomenclature

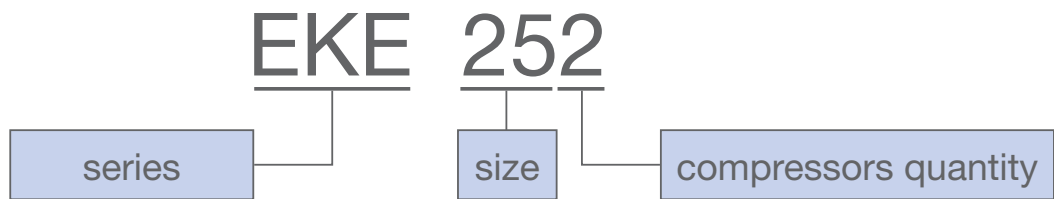

EKE Number of models: **19** - Number of possible configurations: **5000+**

EKE | Standard

COOLING OPERATION LIMITS

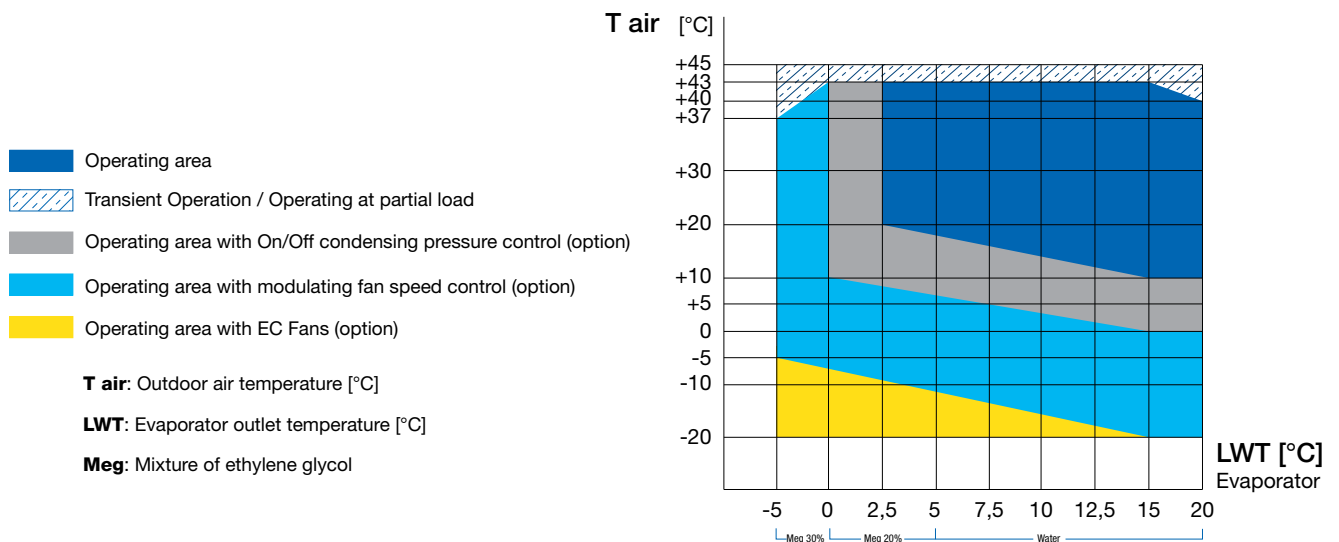

EKE solutions

Euroklimat's **EKE water chillers** perfectly respond to the general requirements of industrial applications, i.e. absolute reliability, the capacity to handle abrupt changes in thermal load and flexibility in operation.

Plastic and Rubber

In plastic and rubber industry there are different ways to produce parts: injection molding, blow molding, thermoforming, extrusion, etc.

In all of these manufacturing alternatives, precise temperature control of tooling equipment (i.e. screw thread sections where plastic flow, mould, etc.), is strategic for the process productivity, dimensional stability and quality of the finished product.

A key role is then fulfilled by water chillers. The use of an efficient thermoregulation is a fundamental condition for the qualitative and aesthetic properties of components in addition to constituting an important factor in reducing the duration of production cycles.

The manufacturing tools often need high available head pressures, to overcome the pressure drops associated with complex mould cooling channels. Great impact of chillers is also in terms of energy efficiency, as cooling typically consumes 11% to 16% of the energy used in a plastics processing plant.



Chemical and Pharmaceutical

Chillers cover a key role in chemical and pharmaceutical industries.

EKE range is optimized for utilization in a multitude of applications and constitutes a reliable and economically

suitable solution for these systems.

The chiller must not only ensure continuity of the process but must also adapt its cooling capacity output as rapidly as possible to match demands fluctuations of the system, ensuring perfect temperature control at all times and in every condition.

EKE chillers represent a valid solution for the chemical and pharmaceutical industry to reduce production cycle times and consequently reduce costs. Some of the possible EKE configurations allow to work with aggressive fluids, pure fluids, in harsh environments thanks to stainless steel or aluminium structure, non-ferrous hydraulic circuit, treated condensing coils and stainless steel No Frost evaporators.

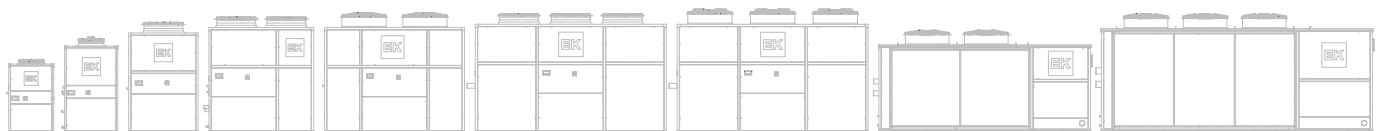

Process Cooling applications

Automotive

The cars are made, always more often, with a series of automated processes that require high precision. Some example of different types of cooling required by processes are the



followings:

- machine tools need the cooling of the mechanical/hydraulic components and of cutting fluids, allowing them to work at high speed, in an accurate and repeatable way, increasing also the tool life and helping to stabilize the size of the finished piece
- laser and painting systems need a stable temperature control in order to obtain a qualitatively optimal result and without defects
- extruders or injection molding machines need temperature stability in order work properly. Chillers used for this purpose are characterized by high head pumps to overcome the pressure drops of the molds cooling channels. They are supplied with safety hydraulic by pass to withstand the pressure changes due to this type of application.

The precise temperature control obtained with EKE chillers allows to increase productivity and life cycle of the machine tool, to reduce the percentage of defective products and danger of plant shutdown.

Food and Beverage

Food and Beverage industries require several kind of cooling, ranging from temperature control to reduce the food and beverage bacterial load, to the quick freezing/cooling of pre-



cooked or frozen foods.

High precision temperature control in the various processes needs to grant increased productivity, ensuring that the product reaches each stage of the production in precise and repeatable conditions, maintaining all the important organoleptic properties of the finished product such as taste, colour and smell.

EKE liquid chillers can be used for cooling various range of products, such as fish, pasta, frozen foods, dairy products, chocolate, meats and beverages.

EKE range offers an elevated system reliability, thanks to innovative design solutions, premium quality components and materials and redundancy of compressors / refrigerant circuits. Furthermore, utmost levels of hygiene, can be granted thanks to the availability of non-ferrous hydraulic circuit and stainless steel No Frost evaporators.

Laboratories

A key factor for good functioning of laboratories and clean rooms environments is to have precise control of temperature, humidity and air quality.

Control of temperature, humidity and air quality can be obtained using a combined installation of EKE chiller and air handling unit, that ensure machinery to remain in optimum working condition and allowing not to compromise the success of the research developments.



Process Cooling applications

Metalworking

Metal industry uses various processes for the transformation of raw materials into finished products. Most of the processings need temperature to be controlled and maintained stable.

Laser

The performance of high power excimer, CO₂, diode or ion lasers is strictly dependent upon the efficiency and precision of the relative cooling systems. The precise and

stable temperature control of the laser allows it to work with the optimal wavelength, with minimal power variations and an optimized beam quality. Chillers ensure system operating stability, thus achieving three goals: maintaining of a preset wavelength, high quality of beam and reduction in the thermal stress to which the laser components are subjected, with a consequent increase in their working life and a decrease in maintenance costs.



Machines Tools

Production processes or individual machine tools require a precise and stable temperature control.

A precision cooling of mechanical components, cutting oils and hydraulic fluids allows machine tools to work at high speeds in an extremely accurate and repeatable manner, increasing tool life and contributing to stabilization of the finished part proportions and dimensions.



Die Casting

It is a manufacturing process that can produce metal parts through the use of reusable molds, called dies. The die casting process involves the use of a furnace, metal, die casting

machine, die and all the auxiliary equipment to keep all of them at the right temperature. The metal is melted in the furnace and then injected into the dies in the die casting machine. If the die temperature is not appropriate troubles such as breaking, damage or malfunction of die and finished product may be caused. For these reasons a precise controlled cooling through an EKE chiller is the solution to obtain the best result.



Process Cooling references

SevenUp Bottling Company | Nigeria

Diter Cuautitlàn Izcalli | Mexico

DS Smith Kaysersberg | Austria



Plastic and Rubber

ENI | Tecnomare

Saint Gobain | Savigliano

Tengizchevroil | Republic of Kazakhstan



Chemical oil & gas

Electrolux | Hungary

Glaxo Smith Kline | Verona

Holland Colours | Holland



Laboratories

Coca Cola Al Ahlia Uae | Dubai

Pepsico | Vietnam

Danone Hayat | Turkey



Food and Beverage

Arvid Svenssons Metallåtervinning | Sweden

TyssenKrupp

Sarok Italia



Metalworking

Euroklimat firmly believes that Customer Satisfaction is an indispensable factor for success. A priority objective to achieve this result is the constant improvement of our products, services and the relative production processes.

For this reason, we work every day to create reliable products that can help our customers in their business.

To achieve this goal, for every single unit we produce there is a lot of work. Therefore, we are pleased to tell you how Euroklimat's chillers are made.

1 Products design and development

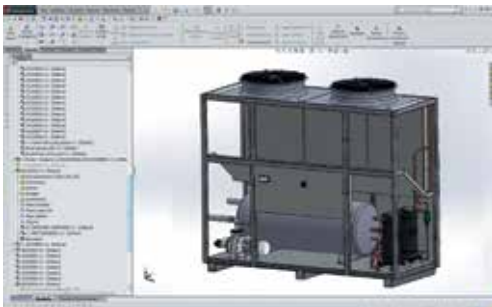

Starting from market's needs we draft a concept which is then transformed into a product. The design involves many people of the company and results in the production of all the necessary documentation such as installation and operating manual, P&ID diagrams, wiring diagrams, 3D drawings and much more.

2 Supply chain



The materials procurement process is the result of a constant partnership with all our suppliers and a careful management of the timing. To do this we use modern manufacturing techniques such as MRP (Material Requirements Planning), trend analysis, which are some of the tools that feed the issuance of orders. Euroklimat's supply chain ends with the reception of the materials and their quality check.

3 Mechanical assembly



The production of the units starts at the mechanical assembly station. Here the structures are assembled and the main components such as compressors and heat exchangers are positioned and fixed.

4 Water circuit



Then the production continues at the water circuit assembly station where all the components of this circuit are mounted.

How it is made

The whole production cycle is subjected to Euroklimat's Quality Management System, that complies with the international standard UNI EN ISO 9001:2015, ensuring quality and long-term reliability.

5

Refrigerant circuit



The next step is at refrigerant circuit assembly station. Here the pipes of the circuit are assembled and brazed welded, which will connect the various elements of the unit, such as compressor(s), condenser(s), evaporator(s), etc. The refrigerant circuit is specifically designed in order to minimize load losses and to avoid capacity reduction. The circuit is entirely made of copper tube brazed with silver alloy and it is isolated on the suction part, in order to avoid condensation.

6

Electrical wiring



Once completed the refrigeration and water circuit, we perform the electrical wiring and the connection between electric board and compressor, fan, pump, etc. Each unit is equipped with electric panel, built, wired and fully tested at the factory. Wiring numeration and optimized layout facilitate troubleshooting. The installed components are identified by nameplates to better identify the application and the type of action.

7

Running test area



The production cycle draws to a close at the running test station. Here all models are individually tested in order to check correct operation, refrigerant charge and settings of microprocessor.

Once all the checks and inspections are completed and successfully passed, the units are disconnected from the testing station and moved to the last station: the shipping area.

8

Final inspection and packaging area



The last phase of the production cycle concerns the finishing of the units and the packaging for shipping. Here all the units are subjected to a final check and prepared for the shipping. If a special packaging has not been requested the standard one is realized with heat-shrinkable plastic film that cover the whole unit and protect it from dust, water and other atmospheric agents. Polystyrol corners are also foreseen in order to protect the unit from potential damages caused during transports. The units are then ready for transportation and final installation.

EKE

EKE: Scroll air-cooled liquid chillers specifically designed for process cooling applications which require high performance, cost reduction and capability to operate in all conditions.



Erp AC/EC FANS

AC (standard): Low speed, axial-flow fans fitted with accident-prevention protective grille on air inlet; directly coupled motor with built-in thermal cut-out. Aerodynamic housing and the profile of blades increase efficiency and decrease noise level. Protection degree IP 54.

EC (optional): Premium-Axial-Fans with bionic shaped blades and high efficient EC (Electronically Commutated) external rotor motors, sealed in protection IP 54 and thermal class THCL 155. The motor efficiency class complies with IE4.



HIGH EFFICIENCY WATER HEAT EXCHANGER

BASE: Brazed plate-type heat exchanger, stainless steel AISI 316 made, complete with water differential pressure switch and air vent valve. The heat exchanger design provides high thermal exchange and high performance results, furthermore it guarantees small dimensions and easy installation and maintenance. Thermally insulated and covered by polyurethane foam to protect from condensation - Standard Thickness: 9 mm. Air vent valve included. The heat exchanger connections are placed near the outside edge of the machine.

INTEGRATA: No Frost evaporator with copper tubes covered by plastic pipe fitted into a carbon steel tank with shell covered with closed-cell neoprene anti-condensate material; complete with water differential pressure switch. For more detailed information see page 14-15.



IE3 CENTRIFUGAL PUMP

Centrifugal pump for circulation of the water. Available with standard pressure or increased pressure configuration. Option with double pump.



The picture refers to the model: EKE - IN/ST/AS 402

The Process Cooling Chiller



ELECTRICAL BOARD

Switchboard made according to standards IEC 204-1/EN60204-1, complete with main isolator switch, door interlock safety device, contactor and protection (fuse) for compressor(s), fan(s) and pump (if present) (overload switch standard for units 21, 31 and 51) and phase monitoring sequence relay. Power supply without neutral.



LARGE SURFACE HEAT EXCHANGER

Finned coil made with copper pipes arranged on staggered rows, mechanically expanded inside a pack of aluminium fins offering a high exchange surface area.



LAST GENERATION SCROLL COMPRESSOR

Hermetic scroll compressor with spirals orbiting specially designed and optimized for use with R410A refrigerant. These compressors, the latest generation, give high energy performance. The electric motor is cooled by refrigerant suction gas and it is protected against any abnormalities with motor over-temperature and over-current devices and protection against excessive gas discharge temperature. The compressor is complete with oil charge. The compressor is fitted on rubber antivibration mounts in order to reduce vibration to the structure. These compressors give a reduced noise level, a limited inrush current and a high MTBF. The electrical terminals of the motor are placed in a dedicated box realized with IP54 protection.



SOLID AND LIGHT STRUCTURE

Structure specifically designed and built to guarantee total resistance to atmospheric agents and corrosion. Base made of galvanized steel sheet, oven-painted with polyurethane powders. Equipped with sturdy support feet that facilitate the handling of the unit and allow a simple and quick installation. Frame made of anodized aluminum profiles, with aluminum alloy corner joints that guarantee excellent mechanical resistance and low weight. Paneling made of galvanized steel, externally coated with plastic film (PVC). Fastening to the aluminum frame is made with stainless steel screws mounted flush on the panels. Internal carpentry in galvanized steel sheet. Rainwater collection tray, in case of outdoor installation, complete with conveyable discharge without the disassembly of any panel. Sealing gaskets fitted on panels' edges, made coextruded plastic with differentiated consistency.



No Frost Evaporator

The **No Frost evaporator** is a Euroklimat's patented heat exchanger with copper tubes covered by plastic pipe fitted into a carbon steel tank with shell covered with closed-cell neoprene anti-condensate material.

The refrigerant evaporates in the tubes, while water flows between tubes and shell. The countercurrent exchange and an optimized exchanger length assure high performances and a suitable superheating of the refrigerant with low pressure drops.

The range of solutions offered is completed with stainless steel special execution.

Euroklimat has developed an entire range of No Frost evaporator for applications in process cooling and conditioning systems.

Our advanced technology, testing programs and long experience have enabled us to patent a unique evaporator for process cooling applications that offers fundamental technical plus, such us:

- » optimal heat transfer efficiency
- » compact dimensions
- » cost-effective performance
- » low refrigerant volume
- » high quality standards



Euroklimat No Frost evaporator – Patent Abstract

An antifreeze evaporator (1) for conditioning systems is described, comprising at least a case (2), at least one pipe (3) - located inside the case (2) - in which the fluid to be cooled flows and a tube bundle (4), located inside the at least one pipe (3) and through which a coolant fluid flows in countercurrent with respect to the fluid to be cooled.

The antifreeze evaporator (1) comprises means (5, 6) suitable to distribute the coolant fluid evenly between the tubes (8) belonging to the at least one tube bundle (4). The antifreeze evaporator (1) advantageously further comprises a linear manifold (12) to which are connected the ends of the tubes (8) belonging to the at least one tube bundle (4) opposite those connected to the distribution means (5, 6).

The pipe (3), containing the tube bundle (4), is preferably wound in a coil and is advantageously made of elastic material to give the antifreeze evaporator (1) anti-icing characteristics.

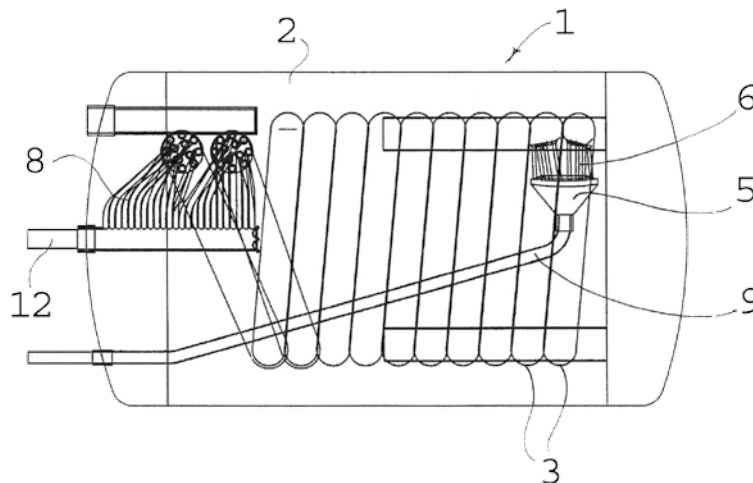

Inspection and test

Production and quality control requirements are very strict in order to guarantee product reliability.

Each No Frost evaporator is subjected to the following tests:

- » pressure test refrigerant side and water side
- » holding charge test of refrigerant side
- » cleaning of refrigerant side

Euroklimat patent



INTEGRATA (I) SOLUTION

Integrata (I) solution already mounts most of the water circuit components in the unit thus making extremely easy and simple the connection to the user system. Moreover, the pump control equipment is fitted inside the electrical board of the unit and the microprocessor control manages the pump starting, timing and all the safety devices of the whole system cutting automatically out the refrigerant circuit when necessary.



MAINTENANCE SIMPLICITY

The arrangement of the components has been studied in detail in order to allow any operation of maintenance in the simplest and safest way.



MULTIPLE CONFIGURATIONS

The various configurations and the vast number of available accessories make these units virtually suitable for all applications and every kind of installation.





Refrigerant
R410A | GWP=2.088



Scroll
Compressor



Axial
fan



Braze plate
heat exchanger



No Frost
evaporator



SEPR

Scroll Air-cooled liquid chillers



Solution

- B - Base
- I - Integrata

Version

- ST - Standard
- LN - Low Noise

Equipment

- AS - Standard equipment

Cooling capacity 12,4 - 61,4 kW

Structure

Structure specifically designed and built to guarantee total resistance to atmospheric agents and corrosion. Base made of galvanized steel sheet, over-painted with polyurethane powders. Frame made of anodized aluminum profiles, with aluminum alloy corner joints. Paneling made of galvanized steel, externally coated with plastic film (PVC).

LN: Low Noise version has panels lined inside with sound-absorbing material, to contain the sound levels of noisier components, such as the compressor.

Compressor

Hermetic scroll compressor complete with motor over-temperature and over-current devices and protection against excessive gas discharge temperature. Fitted on rubber antivibration mounts and complete with oil charge.

AC Fan (standard)

Low speed, axial-flow fans fitted with accident-prevention protective grille on air inlet; directly coupled motor with built-in thermal cut-out. Aerodynamic housing and the profile of blades increase efficiency and decrease noise level. Protection degree IP 54.

EC Fan (optional)

Premium-Axial-Fans with bionic shaped blades and high efficient EC (Electronically Commutated) external rotor motors, sealed in protection IP54 and thermal class THCL 155. The motor efficiency class complies with IE4.

Air heat exchanger

Finned coil made with copper pipes arranged on staggered rows, mechanically expanded inside a pack of aluminium fins offering a high exchange surface area.

Water heat exchanger

Base

Braze plate-type heat exchanger, made of AISI 316 steel complete with water differential pressure switch. Shell covered with closed-cell neoprene anti-condensate material.

Integrata

No Frost evaporator with copper tubes covered by plastic pipe fitted into a carbon steel tank (under request stainless steel is available) with shell covered with closed-cell neoprene anti-condensate material; complete with water differential pressure switch.

Electrical board

Switchboard made according to standards IEC 204-1/EN60204-1, complete with main isolator switch, door interlock safety device, contactor and protection (fuse) for compressor(s), fan(s) and pump (if present) (overload switch standard for units 21, 31 and 51) and phase monitoring sequence relay. Power supply without neutral.

Control

The microprocessor controls the unit capacity by timing the compressors and checks the operating alarms with the possibility to connect to BMS.

Refrigerant circuit

Circuit's main components are: filter drier, moisture-liquid sight glass, safety valve (if applicable), thermostatic expansion valve, HP and LP pressure safety switch. The refrigerant circuit is realized in compliance with PED Directive (2014/68/EU).

Water circuit

Base

Interface to the plant that includes the water fittings of the evaporator only.

Integrata

This solution already mounts most of the water circuit components such as: discharge water valve, water gauge, safety valve water side, water tank, manual by pass valve, manual air venting valve, differential pressure switch, centrifugal pump for circulation of the water and electrical equipment for water pump.

MAIN ACCESSORIES

- Anti-vibration rubber/spring mounts
- Condensing coil protection panel or filter (aluminum mesh)
- Condensing coil with various coatings treatment
- Phase-cut modulating fan speed controller - CPC
- EC Fans (brushless motor)
- Refrigerant gas HP and LP pressure gauges
- Compressor crankcase oil heater
- Electronic expansion valve
- Electromechanical/electronic water flow switch
- Overpressure valve / automatic by-pass
- Double water pump (stand-by) - Standard pressure
- Open expansion tank
- Closed expansion vessel with automatic filling unit
- Min./max. voltage relay
- Advanced electronic controller (c.pCO)
- For the complete list of accessories please see pages 40-41

Technical data

EKE		21	31	51	81	101	121	151	201
Process cooling - Water IN/OUT = 20/15°C									
Cooling capacity ⁽¹⁾	[kW]	12,4	16,4	22,4	30,2	33,2	40,4	42,9	61,4
Compressors power input ⁽¹⁾ (total)	[kW]	2,7	3,2	4,7	5,6	6,7	7,6	8,4	11,7
Process cooling - Water IN/OUT = 12/7°C									
Cooling capacity ⁽²⁾	[kW]	8,6	11,3	15,8	21,8	24,1	29,2	31,2	43,5
Cooling capacity ⁽²⁾ (EN 14511 VALUE)	[kW]	8,5	11,3	15,7	21,6	23,9	29,1	31,0	43,2
Compressors power input ⁽²⁾ (total)	[kW]	3,1	3,7	5,4	6,5	7,8	8,9	9,7	12,9
EER ⁽²⁾	-	2,57	2,80	2,73	3,01	2,84	3,06	2,99	3,01
EUROVENT classification	-	D	C	C	B	C	B	B	B
"Ecodesign" compliance for process application (SEPR)	-	√	√	√	√	√	√	√	√
Refrigerant circuit									
Refrigerant	-	R410A							
GWP	-	2088							
Charge of refrigerant - Solution: Integrata (No Frost)	[kg]	1,7	2,3	2,7	4	4,2	5	5,5	7
CO ₂ equivalent	[t CO ₂]	3,5	4,8	5,6	8,4	8,8	10,4	11,5	14,6
Number of refrigerant circuits	[N°]	1	1	1	1	1	1	1	1
Compressor type	-	SCROLL							
Compressors quantity	[N°]	1	1	1	1	1	1	1	1
Expansion valve type	-	Thermostatic							
Fans quantity / type	-	1 / Axial (AC)							2 / Axial (AC)
Fans power input ⁽¹⁾ (total)	[kW]	0,2	0,4	0,4	0,7	0,7	0,7	0,7	1,5
Total air flow	[m ³ /h]	3.450	6.100	6.100	11.900	11.900	11.350	11.350	22.800
Evaporator water flow ⁽¹⁾	[m ³ /h]	2,2	2,8	3,9	5,2	5,7	7,0	7,4	10,6
Evaporator pressure drop (water side)	[kPa]	22	36	46	52	40	50	39	55
Electrical data									
Power supply	-	400V/3ph/50Hz							
Control Power supply	-	24V-1ph-50Hz / 230V-1ph-50Hz							
Maximum absorbed power without pump	[kW]	4,7	5,5	7,7	10,1	11,6	13,3	14,5	18,4
Locked rotor current - LRA without pump	[A]	48,5	66,9	73,9	101,6	101,6	101,7	101,7	162,3
Maximum absorbed current (full load)	[A]	11,3	13,3	18,3	24,2	27,3	30,8	33,2	44,2
Solution INTEGRATA									
Buffer tank capacity	[L]	30	60	60	160	160	160	160	290
Pump type	-	Peripheral	Centrifugal						
Standard pump									
Motor efficiency	-	-	IE3	IE3	IE3	IE3	IE3	IE3	IE3
Pump motor nominal power input	[kW]	0,6	0,55	0,55	0,9	1,5	1,5	1,5	1,5
Pump motor nominal absorbed current	[A]	2,1	2	2	2,5	4,1	4,1	4,1	4,1
Pump head pressure	[bar]	4,16 / 2,10	2,71 / 2,38	2,60 / 2,15	2,88 / 2,53	3,05 / 2,94	3,05 / 2,84	3,05 / 2,81	3,01 / 2,55
Increased pump									
Motor efficiency	-	IE3	IE3	IE3	IE3	IE3	IE3	IE3	IE3
Pump motor nominal power input	[kW]	1,1	1,1	0,9	1,3	1,3	2,2	2,2	2,2
Pump motor nominal absorbed current	[A]	3,3	3,3	2,5	3,3	3,3	4,7	4,7	4,7
Pump head pressure	[bar]	7,28 / 5,04	6,70 / 3,54	5,61 / 3,24	6,03 / 4,56	5,88 / 4,14	6,52 / 5,68	6,74 / 5,54	6,24 / 4,05
Water connections									
Size (nominal external diameter)	[inch]	1/2" (DN15)	1" (DN 25)	1" (DN 25)	1" 1/4 (DN 32)	1" 1/4 (DN 32)	1" 1/4 (DN 32)	1" 1/4 (DN 32)	1" 1/2 (DN 40)
Noise levels ⁽³⁾									
Total sound power (ST version)	[db(A)]	93	85	85	84	85	86	86	85
Total sound pressure (ST version) - at 1 m distance	[db(A)]	77	69	69	67	69	69	69	68
Total sound pressure (ST version) - at 10 m distance	[db(A)]	61	54	54	52	54	55	55	53
Total sound power (LN version)	[db(A)]	90	82	82	81	82	83	83	82
Total sound pressure (LN version) - at 1 m distance	[db(A)]	74	66	66	64	66	66	66	65
Total sound pressure (LN version) - at 10 m distance	[db(A)]	58	51	51	49	51	52	52	50
Dimensions and weights									
Length	[mm]	830	980	980	1.280	1.280	1.280	1.280	1.930
Width	[mm]	645	795	795	990	990	990	990	990
Height (ST - LN)	[mm]	1.405	1.820	1.820	2.090	2.090	2.090	2.090	2.190
Weight BASE unit / BP (brazed plates evaporator)	[Kg]	185	240	250	400	415	420	430	565
Weight BASE unit / BP (brazed plates evaporator) / LN low noise	[Kg]	187	243	253	404	419	424	434	570
Shipping weight INTEGRATA unit / IN (No-Frost evaporator)	[Kg]	200	265	275	460	480	485	495	660
Working weight INTEGRATA unit / IN (No-Frost evaporator)	[Kg]	230	325	335	620	640	645	655	950
Shipping weight INTEGRATA unit / IN (No-Frost evaporator) / LN low noise	[Kg]	202	268	278	464	484	489	499	665
Working weight INTEGRATA unit / IN (No-Frost evaporator) / LN low noise	[Kg]	232	328	338	624	644	649	659	955

Reference conditions:

(1) Condenser air intake temperature = 25°C - Evaporator water temperature IN/OUT = 20/15°C - Fluid: water - Condensing coil: Cu/Al - Solution: Integrata

(2) Condenser air intake temperature = 35°C - Evaporator water temperature IN/OUT = 12/7°C - Fluid: water - Condensing coil: Cu/Al - Solution: Base

(1) - (2) The declared cooling capacity are not taking into account the pump motor power input (where provided).

(3) Sound power level in compliance with ISO 3744 - Sound pressure level (average value), unit in a free field on a reflective surface; non-binding value obtained from the sound power level. Please refer to technical notes of page 34.

Compliance with "Eco-Design"

The units comply with the European Directive 2009/125/EU, the Commission Regulation (EU) 2016/2281 and with the Harmonized Directives.

The relevant information related to each model (eg.: **SEPR, Seasonal Energy Performance Ratio, Annual electricity consumption, ...**) are published on our website www.euroklimat.it



Refrigerant
R410A | GWP=2.088



Scroll
Compressor



Axial
fan



Braze plate
heat exchanger



No Frost
evaporator



SEPR

Scroll Air-cooled liquid chillers



Solution

- B - Base
- I - Integrata

Version

- ST - Standard
- LN - Low Noise

Equipment

- AS - Standard equipment

Cooling capacity 69,2 - 191,0 kW

Structure

Structure specifically designed and built to guarantee total resistance to atmospheric agents and corrosion. Base made of galvanized steel sheet, over-painted with polyurethane powders. Frame made of anodized aluminum profiles, with aluminum alloy corner joints. Paneling made of galvanized steel, externally coated with plastic film (PVC).

LN: Low Noise version has panels lined inside with sound-absorbing material, to contain the sound levels of noisier components, such as the compressor.

Compressor

Hermetic scroll compressor complete with motor over-temperature and over-current devices and protection against excessive gas discharge temperature. Fitted on rubber antivibration mounts and complete with oil charge.

AC Fan (standard)

Low speed, axial-flow fans fitted with accident-prevention protective grille on air inlet; directly coupled motor with built-in thermal cut-out. Aerodynamic housing and the profile of blades increase efficiency and decrease noise level. Protection degree IP 54.

EC Fan (optional)

Premium-Axial-Fans with bionic shaped blades and high efficient EC (Electronically Commutated) external rotor motors, sealed in protection IP 54 and thermal class THCL 155. The motor efficiency class complies with IE4.

Air heat exchanger

Finned coil made with copper pipes arranged on staggered rows, mechanically expanded inside a pack of aluminium fins offering a high exchange surface area.

Water heat exchanger

Base

Braze plate-type heat exchanger, made of AISI 316 steel complete with water differential pressure switch. Shell covered with closed-cell neoprene anti-condensate material.

Integrata

No Frost evaporator with copper tubes covered by plastic pipe fitted into a carbon steel tank (under request stainless steel is available) with shell covered with closed-cell neoprene anti-condensate material; complete with water differential pressure switch.

Electrical board

Switchboard made according to standards IEC 204-1/EN60204-1, complete with main isolator switch, door interlock safety device, contactor and protection (fuse) for compressor(s), fan(s) and pump (if present) and phase monitoring sequence relay. Power supply without neutral.

Control

The microprocessor controls the unit capacity by timing the compressors and checks the operating alarms with the possibility to connect to BMS.

Refrigerant circuit

Circuit's main components are: filter drier, moisture-liquid sight glass, safety valve (if applicable), electronic expansion valve, HP and LP pressure safety switch. The refrigerant circuit is realized in compliance with PED Directive (2014/68/EU).

Water circuit:

Base

Interface to the plant that includes the water fittings of the evaporator only.

Integrata

This solution already mounts most of the water circuit components such as: discharge water valve, water gauge, safety valve water side, water tank, manual by pass valve, manual air venting valve, differential pressure switch, centrifugal pump for circulation of the water and electrical equipment for water pump.

MAIN ACCESSORIES

- Anti-vibration rubber/spring mounts
- Condensing coil protection panel or filter (aluminum mesh)
- Condensing coil with various coatings treatment
- Phase-cut modulating fan speed controller - CPC
- EC Fans (brushless motor)
- Refrigerant gas HP and LP pressure gauges
- Compressor crankcase oil heater
- Electronic expansion valve
- Electromechanical/electronic water flow switch
- Overpressure valve / automatic by-pass
- Double water pump (stand-by) - Standard pressure
- Open expansion tank
- Closed expansion vessel with automatic filling unit
- Min./max. voltage relay
- Advanced electronic controller (c.pCO)
- For the complete list of accessories please see pages 40-41

Technical data

EKE		252	302	352	402	502	602	702	
Process cooling - Water IN/OUT = 20/15°C									
Cooling capacity ⁽¹⁾	[kW]	69,2	87,8	105,5	120,9	136,5	154,0	191,0	
Compressors power input ⁽¹⁾ (total)	[kW]	13,6	17,0	19,5	21,7	26,2	27,2	35,0	
Process cooling - Water IN/OUT = 12/7°C									
Cooling capacity ⁽²⁾	[kW]	50,3	63,7	76,7	85,8	99,6	112,5	140,7	
Cooling capacity ⁽²⁾ (EN 14511 VALUE)	[kW]	50,0	63,4	76,4	85,5	99,2	112,1	140,2	
Compressors power input ⁽²⁾ (total)	[kW]	15,8	19,6	21,6	23,8	29,7	30,8	39,9	
EER ⁽²⁾	-	2,91	2,90	3,06	3,13	3,14	3,12	3,10	
EUROVENT classification	-	B	B	B	A	A	A	A	
"Ecodesign" compliance for process application (SEPR)	-	√	√	√	√	√	√	√	
Refrigerant circuit									
Refrigerant	-	R410A							
GWP	-	2088							
Charge of refrigerant - Solution: Integrata (No Frost)	[kg]	7,6	10	10,5	11	17	19	21	
CO ₂ equivalent	[t CO ₂]	15,9	20,9	21,9	23,0	35,5	39,7	43,8	
Number of refrigerant circuits	[N°]	1	1	1	1	2	2	2	
Compressor type	-	SCROLL							
Compressors quantity	[N°]	2	2	2	2	2	2	2	
Expansion valve type	-	Electronic							
Fans quantity / type	-	2 / Axial (AC)				3 / Axial (AC)			
Fans power input ⁽¹⁾ (total)	[kW]	1,5	2,3	3,5	3,6	2,0	5,3	5,5	
Total air flow	[m ³ /h]	22.800	28.400	37.600	35.300	37.500	55.500	51.900	
Evaporator water flow ⁽¹⁾	[m ³ /h]	12,0	15,2	18,2	20,9	23,6	26,6	33,0	
Evaporator pressure drop (water side)	[kPa]	54	52	53	54	50	42	50	
Electrical data									
Power supply	-	400V/3ph/50Hz							
Control Power supply	-	24V-1ph-50Hz / 230V-1ph-50Hz							
Maximum absorbed power without pump	[kW]	23,3	29,9	32,8	37,5	40,3	47,9	59,7	
Locked rotor current - LRA without pump	[A]	129,0	136,0	163,3	207,6	279,6	290,4	347,7	
Maximum absorbed current (full load)	[A]	54,7	67,5	79,1	89,5	77,0	87,8	108,8	
Solution INTEGRATA									
Buffer tank capacity	[L]	290	460	460	460	500	500	500	
Pump type	-	Centrifugal							
Standard pump									
Motor efficiency	-	IE3	IE3	IE3	IE3	IE3	IE3	IE3	
Pump motor nominal power input	[kW]	1,8	1,8	3	3	3	4	4	
Pump motor nominal absorbed current	[A]	4,7	4,7	6,4	6,4	6,4	8,7	8,7	
Pump head pressure	[bar]	3,61 / 2,95	3,45 / 2,70	2,88 / 2,67	2,88 / 2,58	2,88 / 2,58	3,60 / 3,16	3,51 / 2,90	
Increased pump									
Motor efficiency	-	IE3	IE3	IE3	IE3	IE3	IE3	IE3	
Pump motor nominal power input	[kW]	2,2	4	5,5	5,5	7,5	7,5	7,5	
Pump motor nominal absorbed current	[A]	4,7	8,7	10,6	10,6	13,6	13,6	13,6	
Pump head pressure	[bar]	6,03 / 3,19	5,07 / 4,37	4,41 / 4,16	4,41 / 4,07	5,26 / 4,90	5,22 / 4,80	5,13 / 4,52	
Water connections									
Size (nominal external diameter)	[inch]	1" 1/2 (DN 40)	2" (DN 50)	2" (DN 50)	2" (DN 50)	3" (DN 80)	3" (DN 80)	3" (DN 80)	
Noise levels ⁽³⁾									
Total sound power (ST version)	[db(A)]	85	85	93	93	92	93	94	
Total sound pressure (ST version) - at 1 m distance	[db(A)]	68	67	75	75	73	74	75	
Total sound pressure (ST version) - at 10 m distance	[db(A)]	53	53	61	61	60	61	62	
Total sound power (LN version)	[db(A)]	82	82	90	90	89	90	91	
Total sound pressure (LN version) - at 1 m distance	[db(A)]	65	64	72	72	70	71	72	
Total sound pressure (LN version) - at 10 m distance	[db(A)]	50	50	58	58	57	58	59	
Dimensions and weights									
Length	[mm]	1.930	2.580	2.580	2.580	3.520	3.520	3.520	
Width	[mm]	990	990	990	990	990	990	990	
Height (ST - LN)	[mm]	2.190	2.268	2.268	2.268	2.250	2.328	2.328	
Weight BASE unit / BP (brazed plates evaporator)	[Kg]	655	885	960	985	1.140	1.200	1.220	
Weight BASE unit / BP (brazed plates evaporator) / LN low noise	[Kg]	660	892	967	992	1.150	1.210	1.230	
Shipping weight INTEGRATA unit / IN (No-Frost evaporator)	[Kg]	750	995	1.100	1.120	1.320	1.380	1.400	
Working weight INTEGRATA unit / IN (No-Frost evaporator)	[Kg]	1.040	1.455	1.560	1.580	1.820	1.880	1.900	
Shipping weight INTEGRATA unit / IN (No-Frost evaporator) / LN low noise	[Kg]	755	1.002	1.107	1.127	1.330	1.390	1.410	
Working weight INTEGRATA unit / IN (No-Frost evaporator) / LN low noise	[Kg]	1.045	1.462	1.567	1.587	1.830	1.890	1.910	

Reference conditions:

(1) Condenser air intake temperature = 25°C - Evaporator water temperature IN/OUT = 20/15°C - Fluid: water - Condensing coil: Cu/Al - Solution: Integrata

(2) Condenser air intake temperature = 35°C - Evaporator water temperature IN/OUT = 12/7°C - Fluid: water - Condensing coil: Cu/Al - Solution: Base

(1) - (2) The declared cooling capacity are not taking into account the pump motor power input (where provided).

(3) Sound power level in compliance with ISO 3744 - Sound pressure level (average value), unit in a free field on a reflective surface; non-binding value obtained from the sound power level. Please refer to technical notes of page 34.

Compliance with "Eco-Design"

The units comply with the European Directive 2009/125/EU, the Commission Regulation (EU) 2016/2281 and with the Harmonized Directives.

The relevant information related to each model (eg.: **SEPR, Seasonal Energy Performance Ratio, Annual electricity consumption, ...**) are published on our website

www.euroklimat.it



Refrigerant
R410A | GWP=2.088



Scroll
Compressor



Axial
fan



Braze plate
heat exchanger



No Frost
evaporator



SEPR

Scroll Air-cooled liquid chillers



Solution

- B - Base
- I - Integrata

Version

- ST - Standard
- LN - Low Noise

Equipment

- AS - Standard equipment

Cooling capacity 252,4 - 390,7 kW

Structure	Structure specifically designed and built to guarantee total resistance to atmospheric agents and corrosion. Base made of galvanized steel sheet, over-painted with polyurethane powders. Frame made of anodized aluminum profiles, with aluminum alloy corner joints. Paneling made of galvanized steel, externally coated with plastic film (PVC). LN: Low Noise version has panels lined inside with sound-absorbing material, to contain the sound levels of noisier components, such as the compressor.
Compressor	Hermetic scroll compressor complete with motor over-temperature and over-current devices and protection against excessive gas discharge temperature. Fitted on rubber antivibration mounts and complete with oil charge.
AC Fan (standard)	Low speed, axial-flow fans fitted with accident-prevention protective grille on air inlet; directly coupled motor with built-in thermal cut-out. Aerodynamic housing and the profile of blades increase efficiency and decrease noise level. Protection degree IP 54.
EC Fan (optional)	Premium-Axial-Fans with bionic shaped blades and high efficient EC (Electronically Commutated) external rotor motors, sealed in protection IP54 and thermal class THCL 155. The motor efficiency class complies with IE4.
Air heat exchanger	Finned coil made with copper pipes arranged on staggered rows, mechanically expanded inside a pack of aluminium fins offering a high exchange surface area.
Water heat exchanger	Base Braze plate-type heat exchanger, made of AISI 316 steel complete with water differential pressure switch. Shell covered with closed-cell neoprene anti-condensate material. Integrata No Frost evaporator with copper tubes covered by plastic pipe fitted into a carbon steel tank (under request stainless steel is available) with shell covered with closed-cell neoprene anti-condensate material; complete with water differential pressure switch.
Electrical board	Switchboard made according to standards IEC 204-1/EN60204-1, complete with main isolator switch, door interlock safety device, contactor and protection (fuse) for compressor(s), fan(s) and pump (if present) and phase monitoring sequence relay. Power supply without neutral.
Control	The microprocessor controls the unit capacity by timing the compressors and checks the operating alarms with the possibility to connect to BMS.
Refrigerant circuit	Circuit's main components are: filter drier, moisture-liquid sight glass, safety valve (if applicable), electronic expansion valve, HP and LP pressure safety switch. The refrigerant circuit is realized in compliance with PED Directive (2014/68/EU).
Water circuit:	Base Interface to the plant that includes the water fittings of the evaporator only. Integrata This solution already mounts most of the water circuit components such as: discharge water valve, water gauge, safety valve water side, water tank, manual by pass valve, manual air venting valve, differential pressure switch, centrifugal pump for circulation of the water and electrical equipment for water pump.

MAIN ACCESSORIES

- Anti-vibration rubber/spring mounts
 - Condensing coil protection panel or filter (aluminum mesh)
 - Condensing coil with various coatings treatment
 - Phase-cut modulating fan speed controller - CPC
 - EC Fans (brushless motor)
 - Refrigerant gas HP and LP pressure gauges
 - Compressor crankcase oil heater
 - Electronic expansion valve
 - Electromechanical/electronic water flow switch
 - Overpressure valve / automatic by-pass
 - Double water pump (stand-by) - Standard pressure
 - Open expansion tank
 - Closed expansion vessel with automatic filling unit
 - Min./max. voltage relay
 - Advanced electronic controller (c.pCO)
- For the complete list of accessories please see pages 40-41

Technical data

EKE		804	1004	1204	1404
Process cooling - Water IN/OUT = 20/15°C					
Cooling capacity ⁽¹⁾	[kW]	252,4	301,4	354,6	390,7
Compressors power input ⁽¹⁾ (total)	[kW]	46,4	55,5	62,2	71,1
Process cooling - Water IN/OUT = 12/7°C					
Cooling capacity ⁽²⁾	[kW]	178,5	219,7	259,8	287,7
Cooling capacity ⁽²⁾ (EN 14511 VALUE)	[kW]	178,0	219,0	259,0	286,9
Compressors power input ⁽²⁾ (total)	[kW]	51,3	63,0	71,5	81,6
EER ⁽²⁾	-	3,09	3,15	3,19	3,14
EUROVENT classification	-	B	A	A	A
"Ecodesign" compliance for process application (SEPR)	-	√	√	√	√
Refrigerant circuit					
Refrigerant	-	R410A			
GWP	-	2088			
Charge of refrigerant - Solution: Integrata (No Frost)	[kg]	30	40	54	58
CO ₂ equivalent	[t CO ₂]	62,6	83,5	112,8	121,1
Number of refrigerant circuits	[N°]	2	2	2	2
Compressor type	-	SCROLL			
Compressors quantity	[N°]	4	4	4	4
Expansion valve type	-	Electronic			
Fans quantity / type	-	4 / Axial (AC)		6 / Axial (AC)	
Fans power input ⁽¹⁾ (total)	[kW]	6,6	6,8	9,9	9,9
Total air flow	[m ³ /h]	82.600	79.800	125.400	125.400
Evaporator water flow ⁽¹⁾	[m ³ /h]	43,6	52,1	61,3	67,5
Evaporator pressure drop (water side)	[kPa]	48	55	51	56
Electrical data					
Power supply	-	400V/3ph/50Hz			
Control Power supply	-	24V-1ph-50Hz / 230V-1ph-50Hz			
Maximum absorbed power without pump	[kW]	74,4	92,0	106,7	118,3
Locked rotor current - LRA without pump	[A]	296,2	370,2	434,3	455,1
Maximum absorbed current (full load)	[A]	178,1	167,6	195,4	216,2
Solution INTEGRATA					
Buffer tank capacity	[L]	920	920	1000	1000
Pump type	-	Centrifugal			
Standard pump					
Motor efficiency	-	IE3	IE3	IE3	IE3
Pump motor nominal power input	[kW]	5,5	5,5	7,5	7,5
Pump motor nominal absorbed current	[A]	10,6	10,6	13,6	13,6
Pump head pressure	[bar]	3,15 / 2,76	3,15 / 2,50	3,66 / 2,81	3,61 / 2,63
Increased pump					
Motor efficiency	-	IE3	IE3	IE3	IE3
Pump motor nominal power input	[kW]	11	11	11	11
Pump motor nominal absorbed current	[A]	21,3	21,3	21,3	21,3
Pump head pressure	[bar]	5,44 / 5,01	5,44 / 4,72	5,38 / 4,34	5,32 / 4,14
Water connections					
Size (nominal external diameter)	[inch]	3" (DN 80)	3" (DN 80)	3" (DN 80)	4" (DN 100)
Noise levels ⁽³⁾					
Total sound power (ST version)	[db(A)]	95	95	95	95
Total sound pressure (ST version) - at 1 m distance	[db(A)]	75	76	75	75
Total sound pressure (ST version) - at 10 m distance	[db(A)]	62	63	63	63
Total sound power (LN version)	[db(A)]	92	92	92	92
Total sound pressure (LN version) - at 1 m distance	[db(A)]	72	73	72	72
Total sound pressure (LN version) - at 10 m distance	[db(A)]	59	60	60	60
Dimensions and weights					
Length	[mm]	3.900	3.900	5.000	5.000
Width	[mm]	2.000	2.000	2.000	2.000
Height (ST - LN)	[mm]	1.946	1.946	2.245	2.245
Weight BASE unit / BP (brazed plates evaporator)	[Kg]	2.040	2.065	2.260	2.380
Weight BASE unit / BP (brazed plates evaporator) / LN low noise	[Kg]	2.048	2.073	2.270	2.390
Shipping weight INTEGRATA unit / IN (No-Frost evaporator)	[Kg]	2.280	2.300	2.590	2.700
Working weight INTEGRATA unit / IN (No-Frost evaporator)	[Kg]	3.200	3.220	3.590	3.700
Shipping weight INTEGRATA unit / IN (No-Frost evaporator) / LN low noise	[Kg]	2.288	2.308	2.600	2.710
Working weight INTEGRATA unit / IN (No-Frost evaporator) / LN low noise	[Kg]	3.208	3.228	3.600	3.710

Reference conditions:

(1) Condenser air intake temperature = 25°C - Evaporator water temperature IN/OUT = 20/15°C - Fluid: water - Condensing coil: Cu/Al - Solution: Integrata

(2) Condenser air intake temperature = 35°C - Evaporator water temperature IN/OUT = 12/7°C - Fluid: water - Condensing coil: Cu/Al - Solution: Base

(1) - (2) The declared cooling capacity are not taking into account the pump motor power input (where provided).

(3) Sound power level in compliance with ISO 3744 - Sound pressure level (average value), unit in a free field on a reflective surface; non-binding value obtained from the sound power level. Please refer to technical notes of page 34.

Compliance with "Eco-Design"

The units comply with the European Directive 2009/125/EU, the Commission Regulation (EU) 2016/2281 and with the Harmonized Directives.

The relevant information related to each model (eg.: **SEPR, Seasonal Energy Performance Ratio, Annual electricity consumption, ...**) are published on our website

www.euroklimat.it

EKE

Performance tables by model

Model	LWT	Condenser air intake temperature [°C]										
		20		25		30		35		40		
	°C	Cc	Pi	Cc	Pi	Cc	Pi	Cc	Pi	Cc	Pi	
EKE 21	5	10.0	2.3	9.3	2.5	8.7	2.8	8.1	3.1	7.5	3.4	Ethylene Glycol 5%
	6	10.3	2.3	9.6	2.5	8.9	2.8	8.3	3.1	7.7	3.5	
	7	10.6	2.3	9.9	2.6	9.2	2.8	8.6	3.1	7.9	3.5	Water
	8	10.9	2.4	10.2	2.6	9.5	2.8	8.8	3.1	8.2	3.5	
	9	11.2	2.4	10.5	2.6	9.8	2.9	9.1	3.2	8.4	3.5	
	10	11.5	2.4	10.8	2.6	10.1	2.9	9.4	3.2	8.7	3.5	
	12	12.2	2.4	11.4	2.6	10.7	2.9	9.9	3.2	9.2	3.6	
15	13.2	2.5	12.4	2.7	11.6	3.0	10.8	3.3	10.0	3.7		

Model	LWT	Condenser air intake temperature [°C]										
		20		25		30		35		40		
	°C	Cc	Pi	Cc	Pi	Cc	Pi	Cc	Pi	Cc	Pi	
EKE 31	5	13.3	2.7	12.4	2.9	11.5	3.3	10.7	3.6	9.9	4.0	Ethylene Glycol 5%
	6	13.7	2.7	12.8	3.0	11.9	3.3	11.0	3.6	10.2	4.0	
	7	14.1	2.7	13.2	3.0	12.2	3.3	11.3	3.7	10.5	4.1	Water
	8	14.5	2.7	13.5	3.0	12.6	3.3	11.7	3.7	10.8	4.1	
	9	14.9	2.8	13.9	3.0	13.0	3.3	12.0	3.7	11.1	4.1	
	10	15.3	2.8	14.3	3.1	13.3	3.4	12.4	3.7	11.5	4.1	
	12	16.2	2.8	15.1	3.1	14.1	3.4	13.1	3.8	12.1	4.2	
15	17.5	2.9	16.4	3.2	15.3	3.5	14.2	3.9	13.2	4.3		

Model	LWT	Condenser air intake temperature [°C]										
		20		25		30		35		40		
	°C	Cc	Pi	Cc	Pi	Cc	Pi	Cc	Pi	Cc	Pi	
EKE 51	5	18.5	3.9	17.3	4.3	16.1	4.8	14.9	5.3	13.8	5.9	Ethylene Glycol 5%
	6	19.0	4.0	17.8	4.3	16.5	4.8	15.3	5.3	14.2	5.9	
	7	19.6	4.0	18.3	4.4	17.0	4.8	15.8	5.4	14.6	6.0	Water
	8	20.1	4.0	18.8	4.4	17.5	4.9	16.2	5.4	15.0	6.0	
	9	20.6	4.1	19.3	4.5	17.9	4.9	16.6	5.5	15.4	6.1	
	10	21.2	4.1	19.8	4.5	18.4	5.0	17.1	5.5	15.8	6.1	
	12	22.3	4.2	20.8	4.6	19.4	5.1	18.0	5.6	16.7	6.2	
15	23.9	4.3	22.4	4.7	20.9	5.2	19.4	5.8	18.0	6.4		

Model	LWT	Condenser air intake temperature [°C]										
		20		25		30		35		40		
	°C	Cc	Pi	Cc	Pi	Cc	Pi	Cc	Pi	Cc	Pi	
EKE 81	5	24.5	4.9	23.1	5.3	21.8	5.8	20.6	6.5	19.4	7.2	Ethylene Glycol 5%
	6	25.1	4.8	23.8	5.3	22.4	5.9	21.2	6.5	19.9	7.2	
	7	25.9	4.9	24.5	5.3	23.1	5.9	21.8	6.5	20.5	7.3	Water
	8	26.6	4.9	25.1	5.3	23.7	5.9	22.4	6.6	21.1	7.3	
	9	27.3	4.9	25.8	5.4	24.4	5.9	23.0	6.6	21.6	7.4	
	10	28.0	4.9	26.5	5.4	25.0	6.0	23.6	6.6	22.2	7.4	
	12	29.5	4.9	27.9	5.5	26.4	6.0	24.9	6.7	23.4	7.5	
15	31.9	5.0	30.2	5.6	28.5	6.2	26.9	6.9	25.3	7.6		

Model	LWT	Condenser air intake temperature [°C]										
		20		25		30		35		40		
	°C	Cc	Pi	Cc	Pi	Cc	Pi	Cc	Pi	Cc	Pi	
EKE 101	5	27.1	5.7	25.6	6.3	24.2	6.9	22.8	7.7	21.5	8.5	Ethylene Glycol 5%
	6	27.8	5.7	26.3	6.3	24.8	7.0	23.4	7.7	22.0	8.6	
	7	28.6	5.7	27.1	6.3	25.5	7.0	24.1	7.8	22.7	8.7	Water
	8	29.4	5.8	27.8	6.3	26.2	7.0	24.7	7.8	23.3	8.7	
	9	30.1	5.8	28.5	6.4	26.9	7.1	25.4	7.9	23.9	8.8	
	10	30.9	5.8	29.3	6.4	27.6	7.1	26.0	7.9	24.5	8.8	
	12	32.5	5.9	30.8	6.5	29.1	7.2	27.4	8.0	25.8	9.0	
15	35.1	6.1	33.2	6.7	31.4	7.4	29.6	8.2	27.8	9.1		

Performance tables by model

Model	LWT	Condenser air intake temperature [°C]										
		20		25		30		35		40		
	°C	Cc	Pi	Cc	Pi	Cc	Pi	Cc	Pi	Cc	Pi	
EKE 121	5	32.9	6.5	31.1	7.2	29.3	7.9	27.7	8.8	26.1	9.7	Ethylene Glycol 5%
	6	33.7	6.5	31.9	7.2	30.1	7.9	28.4	8.8	26.8	9.8	
	7	34.7	6.6	32.8	7.2	31.0	8.0	29.2	8.9	27.5	9.9	
	8	35.6	6.6	33.7	7.2	31.8	8.0	30.0	8.9	28.3	9.9	Water
	9	36.6	6.6	34.6	7.3	32.7	8.1	30.8	9.0	29.0	10.0	
	10	37.6	6.6	35.5	7.3	33.6	8.1	31.6	9.0	29.8	10.1	
	12	39.5	6.7	37.4	7.4	35.4	8.2	33.3	9.2	31.4	10.2	
15	42.7	6.9	40.4	7.6	38.2	8.4	36.0	9.4	33.9	10.4		

Model	LWT	Condenser air intake temperature [°C]										
		20		25		30		35		40		
	°C	Cc	Pi	Cc	Pi	Cc	Pi	Cc	Pi	Cc	Pi	
EKE 151	5	7.1	33.2	7.8	31.3	8.7	29.5	9.6	27.8	10.7	00,0	Ethylene Glycol 5%
	6	7.1	34.1	7.9	32.1	8.7	30.3	9.7	28.5	10.7	00,0	
	7	7.2	35.0	7.9	33.1	8.8	31.2	9.7	29.3	10.8	00,0	
	8	7.2	35.9	7.9	33.9	8.8	32.0	9.8	30.1	10.9	00,0	Water
	9	7.2	36.9	8.0	34.8	8.9	32.8	9.9	30.9	11.0	00,0	
	10	7.3	37.9	8.1	35.7	8.9	33.7	9.9	31.7	11.1	00,0	
	12	7.4	39.8	8.2	37.6	9.1	35.5	10.1	33.4	11.2	00,0	
15	7.6	42.9	8.4	40.5	9.3	38.2	10.3	35.9	11.5	00,0		

Model	LWT	Condenser air intake temperature [°C]										
		20		25		30		35		40		
	°C	Cc	Pi	Cc	Pi	Cc	Pi	Cc	Pi	Cc	Pi	
EKE 201	5	52.5	10.0	48.5	10.8	44.8	11.7	41.2	12.7	37.7	13.9	Ethylene Glycol 5%
	6	53.7	10.0	49.7	10.8	45.9	11.8	42.3	12.8	38.8	14.0	
	7	55.0	10.1	51.0	10.9	47.2	11.9	43.5	12.9	39.9	14.1	
	8	56.3	10.2	52.3	11.0	48.4	12.0	44.6	13.0	41.0	14.2	Water
	9	57.6	10.3	53.5	11.1	49.6	12.1	45.8	13.1	42.2	14.3	
	10	58.9	10.4	54.8	11.2	50.8	12.2	47.0	13.2	43.3	14.4	
	12	61.6	10.6	57.4	11.4	53.3	12.4	49.3	13.5	45.6	14.7	
15	65.8	10.9	61.4	11.7	57.1	12.7	53.0	13.8	49.0	15.0		

Model	LWT	Condenser air intake temperature [°C]										
		20		25		30		35		40		
	°C	Cc	Pi	Cc	Pi	Cc	Pi	Cc	Pi	Cc	Pi	
EKE 252	5	56.6	11.5	53.5	12.7	50.5	14.0	47.6	15.6	44.9	17.3	Ethylene Glycol 5%
	6	58.1	11.6	55.0	12.7	51.9	14.1	48.9	15.6	46.1	17.4	
	7	59.7	11.6	56.5	12.8	53.4	14.2	50.3	15.8	47.3	17.5	
	8	61.3	11.7	58.0	12.9	54.8	14.3	51.6	15.9	48.6	17.7	Water
	9	62.9	11.7	59.5	13.0	56.2	14.4	53.0	16.0	49.9	17.8	
	10	64.5	11.8	61.1	13.1	57.7	14.5	54.4	16.1	51.2	17.9	
	12	67.9	12.0	64.3	13.3	60.7	14.7	57.2	16.3	53.8	18.2	
15	73.1	12.4	69.2	13.6	65.4	15.1	61.6	16.7	58.0	18.6		

Model	LWT	Condenser air intake temperature [°C]										
		20		25		30		35		40		
	°C	Cc	Pi	Cc	Pi	Cc	Pi	Cc	Pi	Cc	Pi	
EKE 302	5	71.7	14.4	67.8	15.8	64.0	17.5	60.4	19.4	56.8	21.6	Ethylene Glycol 5%
	6	73.6	14.4	69.6	15.9	65.8	17.6	62.0	19.5	58.4	21.7	
	7	75.7	14.5	71.6	16.0	67.6	17.7	63.7	19.6	60.0	21.9	
	8	77.7	14.6	73.5	16.1	69.4	17.8	65.4	19.8	61.6	22.0	Water
	9	79.7	14.6	75.5	16.2	71.3	17.9	67.2	19.9	63.2	22.2	
	10	81.8	14.7	77.4	16.3	73.1	18.0	68.9	20.1	64.9	22.3	
	12	86.1	15.0	81.5	16.5	77.0	18.3	72.5	20.4	68.3	22.6	
15	92.7	15.4	87.8	17.0	83.0	18.8	78.2	20.8	73.6	23.1		

ETHYLENE GLYCOL Mixture (Meg) - Correction Factor

If a Meg is used instead of water, it causes a variation in the performance of the unit.

For correct data please use the Correction Factor indicated in the following table:

	0 (water)	Meg 20%	Meg 30%	Meg 40% ⁽¹⁾
Freezing point	0°C	-8,9°C	-15,8°C	-24,8°C
CcCF	1	0,980	0,974	0,965

CcCF: Correction factor for cooling capacity

⁽¹⁾ For Meg = 40% and for data concerning other kind of anti-freeze solutions please contact our Sales Dept.

Notes:
Cc = Cooling capacity [kW]
Pi = Compressor(s) power input [kW]
LWT = Evaporator Leaving Water Temperature

EKE

Performance tables by model

Model	LWT	Condenser air intake temperature [°C]										
		20		25		30		35		40		
	°C	Cc	Pi	Cc	Pi	Cc	Pi	Cc	Pi	Cc	Pi	
EKE 352	5	87.5	16.3	82.4	17.7	77.5	19.4	72.7	21.2	68.1	23.3	Ethylene Glycol 5%
	6	89.6	16.4	84.5	17.9	79.5	19.5	74.6	21.4	70.0	23.5	
	7	91.9	16.6	86.7	18.0	81.7	19.7	76.7	21.6	72.0	23.7	
	8	94.2	16.7	88.9	18.2	83.8	19.9	78.8	21.7	74.0	23.8	Water
	9	96.5	16.9	91.1	18.4	85.9	20.0	80.8	21.9	76.0	24.0	
	10	98.8	17.1	93.4	18.5	88.1	20.2	83.0	22.1	78.0	24.2	
	12	103.7	17.4	98.1	18.9	92.7	20.6	87.4	22.5	82.3	24.6	
15	111.3	18.0	105.5	19.5	99.8	21.2	94.3	23.1	89.0	25.2		

Model	LWT	Condenser air intake temperature [°C]										
		20		25		30		35		40		
	°C	Cc	Pi	Cc	Pi	Cc	Pi	Cc	Pi	Cc	Pi	
EKE 402	5	103.4	18.4	95.8	19.8	88.4	21.5	81.3	23.4	74.6	25.5	Ethylene Glycol 5%
	6	105.8	18.5	98.1	20.0	90.6	21.7	83.5	23.6	76.7	25.7	
	7	108.4	18.7	100.6	20.2	93.1	21.9	85.8	23.8	79.0	26.0	
	8	110.9	18.8	103.1	20.3	95.4	22.1	88.1	24.0	81.1	26.2	Water
	9	113.5	19.0	105.6	20.5	97.8	22.2	90.4	24.2	83.3	26.4	
	10	116.1	19.2	108.1	20.7	100.2	22.4	92.7	24.4	85.5	26.6	
	12	121.3	19.5	113.1	21.1	105.1	22.8	97.4	24.8	90.0	27.0	
15	129.4	20.1	120.9	21.7	112.6	23.4	104.5	25.5	96.8	27.7		

Model	LWT	Condenser air intake temperature [°C]										
		20		25		30		35		40		
	°C	Cc	Pi	Cc	Pi	Cc	Pi	Cc	Pi	Cc	Pi	
EKE 502	5	112.9	21.6	107.2	23.9	101.0	26.4	94.4	29.2	87.7	32.4	Ethylene Glycol 5%
	6	115.8	21.8	110.0	24.1	103.7	26.6	96.9	29.4	90.0	32.6	
	7	119.0	22.0	113.0	24.3	106.5	26.8	99.6	29.7	92.5	32.8	
	8	122.0	22.2	115.8	24.5	109.2	27.1	102.1	29.9	94.9	33.1	Water
	9	125.1	22.5	118.7	24.7	111.9	27.3	104.7	30.1	97.3	33.3	
	10	128.1	22.7	121.6	25.0	114.6	27.5	107.3	30.4	99.8	33.6	
	12	134.4	23.1	127.5	25.5	120.2	28.0	112.6	30.9	104.7	34.1	
15	143.9	23.9	136.5	26.2	128.7	28.8	120.7	31.8	112.3	35.0		

Model	LWT	Condenser air intake temperature [°C]										
		20		25		30		35		40		
	°C	Cc	Pi	Cc	Pi	Cc	Pi	Cc	Pi	Cc	Pi	
EKE 602	5	126.0	22.5	120.0	24.8	113.6	27.4	106.5	30.3	99.3	33.5	Ethylene Glycol 5%
	6	129.3	22.7	123.2	25.1	116.6	27.6	109.4	30.5	102.0	33.7	
	7	132.9	23.0	126.7	25.3	119.8	27.9	112.5	30.8	104.9	34.0	
	8	136.4	23.2	129.9	25.5	122.9	28.1	115.4	31.0	107.7	34.2	Water
	9	139.9	23.4	133.3	25.7	126.1	28.3	118.4	31.2	110.5	34.5	
	10	143.4	23.6	136.6	26.0	129.3	28.6	121.4	31.5	113.4	34.7	
	12	150.6	24.1	143.5	26.5	135.7	29.1	127.5	32.0	119.2	35.3	
15	161.8	24.9	154.0	27.2	145.7	29.9	137.0	32.9	128.0	36.2		

Model	LWT	Condenser air intake temperature [°C]										
		20		25		30		35		40		
	°C	Cc	Pi	Cc	Pi	Cc	Pi	Cc	Pi	Cc	Pi	
EKE 702	5	156.9	29.4	149.8	32.4	141.9	35.7	133.4	39.3	124.4	43.5	Ethylene Glycol 5%
	6	160.9	29.6	153.6	32.6	145.6	35.9	136.9	39.6	127.7	43.7	
	7	165.3	29.9	157.8	32.9	149.6	36.2	140.7	39.9	131.3	44.0	
	8	169.4	30.1	161.8	33.1	153.4	36.4	144.3	40.1	134.8	44.3	Water
	9	173.6	30.3	165.9	33.4	157.3	36.7	147.9	40.4	138.3	44.5	
	10	177.9	30.6	169.9	33.6	161.2	36.9	151.6	40.6	141.9	44.8	
	12	186.5	31.1	178.2	34.1	169.1	37.5	159.2	41.2	149.1	45.4	
15	199.9	31.9	191.0	35.0	181.3	38.3	170.9	42.1	160.1	46.3		

Performance tables by model

Model	LWT	Condenser air intake temperature [°C]										
		20		25		30		35		40		
	°C	Cc	Pi	Cc	Pi	Cc	Pi	Cc	Pi	Cc	Pi	
EKE 804	5	215.4	39.5	199.3	42.7	183.9	46.3	169.0	50.5	155.0	55.1	Ethylene Glycol 5%
	6	220.4	39.8	204.2	43.0	188.6	46.7	173.6	50.8	159.4	55.5	
	7	225.9	40.1	209.6	43.4	193.7	47.1	178.5	51.3	164.1	56.0	
	8	231.2	40.4	214.7	43.7	198.7	47.4	183.3	51.6	168.6	56.4	Water
	9	236.6	40.8	219.9	44.1	203.6	47.8	188.0	52.0	173.2	56.8	
	10	242.1	41.1	225.2	44.4	208.7	48.2	192.9	52.5	177.8	57.2	
	12	253.2	41.8	236.0	45.2	219.0	49.0	202.8	53.3	187.2	58.1	
15	270.4	43.0	252.4	46.4	234.8	50.3	217.8	54.6	201.5	59.5		

Model	LWT	Condenser air intake temperature [°C]										
		20		25		30		35		40		
	°C	Cc	Pi	Cc	Pi	Cc	Pi	Cc	Pi	Cc	Pi	
EKE 1004	5	245.7	46.0	234.2	50.8	221.6	56.1	208.0	62.0	193.8	68.7	Ethylene Glycol 5%
	6	252.3	46.4	240.5	51.2	227.6	56.5	213.6	62.5	199.1	69.1	
	7	259.5	46.9	247.3	51.7	234.0	57.0	219.7	63.0	204.9	69.6	
	8	266.3	47.3	253.8	52.1	240.2	57.4	225.5	63.4	210.3	70.1	Water
	9	273.2	47.7	260.3	52.5	246.4	57.9	231.3	63.9	215.9	70.6	
	10	280.1	48.2	267.0	53.0	252.7	58.4	237.2	64.4	221.6	71.1	
	12	294.4	49.1	280.5	54.0	265.5	59.4	249.4	65.4	233.0	72.2	
15	316.5	50.6	301.4	55.5	285.2	61.0	268.1	67.1	250.6	73.9		

Model	LWT	Condenser air intake temperature [°C]										
		20		25		30		35		40		
	°C	Cc	Pi	Cc	Pi	Cc	Pi	Cc	Pi	Cc	Pi	
EKE 1204	5	287.7	52.4	274.9	57.9	261.0	63.9	245.8	70.6	229.4	78.2	Ethylene Glycol 5%
	6	295.4	52.8	282.4	58.3	268.1	64.3	252.5	71.0	235.8	78.6	
	7	303.7	53.2	290.4	58.7	275.7	64.7	259.8	71.5	242.7	79.1	
	8	311.7	53.6	298.0	59.1	283.0	65.1	266.7	71.9	249.2	79.5	Water
	9	319.8	54.0	305.8	59.5	290.5	65.6	273.7	72.3	255.9	80.0	
	10	327.9	54.4	313.6	59.9	298.0	66.0	280.9	72.8	262.7	80.4	
	12	344.7	55.2	329.7	60.8	313.3	66.9	295.4	73.7	276.6	81.4	
15	370.6	56.6	354.6	62.2	336.9	68.3	317.8	75.2	298.0	82.9		

Model	LWT	Condenser air intake temperature [°C]										
		20		25		30		35		40		
	°C	Cc	Pi	Cc	Pi	Cc	Pi	Cc	Pi	Cc	Pi	
EKE 1404	5	319.3	60.2	305.1	66.3	289.6	73.1	272.6	80.7	254.4	89.2	Ethylene Glycol 5%
	6	327.6	60.6	313.1	66.8	297.2	73.6	279.9	81.1	261.3	89.7	
	7	336.5	61.0	321.7	67.2	305.5	74.0	287.7	81.6	268.8	90.2	
	8	345.1	61.4	330.0	67.7	313.4	74.5	295.2	82.1	276.0	90.7	Water
	9	353.7	61.9	338.4	68.1	321.4	75.0	302.9	82.6	283.2	91.2	
	10	362.5	62.3	346.9	68.6	329.5	75.5	310.6	83.1	290.6	91.7	
	12	380.5	63.2	364.1	69.5	346.0	76.5	326.3	84.1	305.7	92.8	
15	408.1	64.7	390.7	71.1	371.4	78.0	350.4	85.8	329.0	94.5		

ETHYLENE GLYCOL Mixture (Meg) - Correction Factor

If a Meg is used instead of water, it causes a variation in the performance of the unit.

For correct data please use the Correction Factor indicated in the following table:

	0 (water)	Meg 20%	Meg 30%	Meg 40% ⁽¹⁾
Freezing point	0°C	-8.9°C	-15.8°C	-24.8°C
CcCF	1	0,980	0,974	0,965

CcCF: Correction factor for cooling capacity

⁽¹⁾ For Meg = 40% and for data concerning other kind of anti-freeze solutions please contact our Sales Dept.

Notes:

Cc = Cooling capacity [kW]

Pi = Compressor(s) power input [kW]

LWT = Evaporator Leaving Water Temperature

EKE

Performance tables by temperature conditions

Model	Eg5% 10/5 air 20°C		Eg5% 10/5 air 25°C		Eg5% 10/5 air 30°C		Eg5% 10/5 air 35°C		Eg5% 10/5 air 40°C	
	Cc	Pi	Cc	Pi	Cc	Pi	Cc	Pi	Cc	Pi
EKE 21	10.0	2.3	9.3	2.5	8.7	2.8	8.1	3.1	7.5	3.4
EKE 31	13.3	2.7	12.4	2.9	11.5	3.3	10.7	3.6	9.9	4.0
EKE 51	18.5	3.9	17.3	4.3	16.1	4.8	14.9	5.3	13.8	5.9
EKE 81	24.5	4.9	23.1	5.3	21.8	5.8	20.6	6.5	19.4	7.2
EKE 101	27.1	5.7	25.6	6.3	24.2	6.9	22.8	7.7	21.5	8.5
EKE 121	32.9	6.5	31.1	7.2	29.3	7.9	27.7	8.8	26.1	9.7
EKE 151	35.1	7.1	33.2	7.8	31.3	8.7	29.5	9.6	27.8	10.7
EKE 201	52.5	10.0	48.5	10.8	44.8	11.7	41.2	12.7	37.7	13.9
EKE 252	56.6	11.5	53.5	12.7	50.5	14.0	47.6	15.6	44.9	17.3
EKE 302	71.7	14.4	67.8	15.8	64.0	17.5	60.4	19.4	56.8	21.6
EKE 352	87.5	16.3	82.4	17.7	77.5	19.4	72.7	21.2	68.1	23.3
EKE 402	103.4	18.4	95.8	19.8	88.4	21.5	81.3	23.4	74.6	25.5
EKE 502	112.9	21.6	107.2	23.9	101.0	26.4	94.4	29.2	87.7	32.4
EKE 602	126.0	22.5	120.0	24.8	113.6	27.4	106.5	30.3	99.3	33.5
EKE 702	156.9	29.4	149.8	32.4	141.9	35.7	133.4	39.3	124.4	43.5
EKE 804	215.4	39.5	199.3	42.7	183.9	46.3	169.0	50.5	155.0	55.1
EKE 1004	245.7	46.0	234.2	50.8	221.6	56.1	208.0	62.0	193.8	68.7
EKE 1204	287.7	52.4	274.9	57.9	261.0	63.9	245.8	70.6	229.4	78.2
EKE 1404	319.3	60.2	305.1	66.3	289.6	73.1	272.6	80.7	254.4	89.2

Model	Eg5% 11/6 air 20°C		Eg5% 11/6 air 25°C		Eg5% 11/6 air 30°C		Eg5% 11/6 air 35°C		Eg5% 11/6 air 40°C	
	Cc	Pi	Cc	Pi	Cc	Pi	Cc	Pi	Cc	Pi
EKE 21	10.3	2.3	9.6	2.5	8.9	2.8	8.3	3.1	7.7	3.5
EKE 31	13.7	2.7	12.8	3.0	11.9	3.3	11.0	3.6	10.2	4.0
EKE 51	19.0	4.0	17.8	4.3	16.5	4.8	15.3	5.3	14.2	5.9
EKE 81	25.1	4.8	23.8	5.3	22.4	5.9	21.2	6.5	19.9	7.2
EKE 101	27.8	5.7	26.3	6.3	24.8	7.0	23.4	7.7	22.0	8.6
EKE 121	33.7	6.5	31.9	7.2	30.1	7.9	28.4	8.8	26.8	9.8
EKE 151	36.0	7.1	34.1	7.9	32.1	8.7	30.3	9.7	28.5	10.7
EKE 201	53.7	10.0	49.7	10.8	45.9	11.8	42.3	12.8	38.8	14.0
EKE 252	58.1	11.6	55.0	12.7	51.9	14.1	48.9	15.6	46.1	17.4
EKE 302	73.6	14.4	69.6	15.9	65.8	17.6	62.0	19.5	58.4	21.7
EKE 352	89.6	16.4	84.5	17.9	79.5	19.5	74.6	21.4	70.0	23.5
EKE 402	105.8	18.5	98.1	20.0	90.6	21.7	83.5	23.6	76.7	25.7
EKE 502	115.8	21.8	110.0	24.1	103.7	26.6	96.9	29.4	90.0	32.6
EKE 602	129.3	22.7	123.2	25.1	116.6	27.6	109.4	30.5	102.0	33.7
EKE 702	160.9	29.6	153.6	32.6	145.6	35.9	136.9	39.6	127.7	43.7
EKE 804	220.4	39.8	204.2	43.0	188.6	46.7	173.6	50.8	159.4	55.5
EKE 1004	252.3	46.4	240.5	51.2	227.6	56.5	213.6	62.5	199.1	69.1
EKE 1204	295.4	52.8	282.4	58.3	268.1	64.3	252.5	71.0	235.8	78.6
EKE 1404	327.6	60.6	313.1	66.8	297.2	73.6	0,0	0,0	261.3	89.7



Euroklimat has developed an online software called "wEKool" that allows you to select the chiller model closest to the project conditions.

For more information, please contact your sales representative.

Performance tables by temperature conditions

Model	Water 12/7 air 20°C		Water 12/7 air 25°C		Water 12/7 air 30°C		Water 12/7 air 35°C		Water 12/7 air 40°C	
	Cc	Pi	Cc	Pi	Cc	Pi	Cc	Pi	Cc	Pi
EKE 21	10.6	2.3	9.9	2.6	9.2	2.8	8.6	3.1	7.9	3.5
EKE 31	14.1	2.7	13.2	3.0	12.2	3.3	11.3	3.7	10.5	4.1
EKE 51	19.6	4.0	18.3	4.4	17.0	4.8	15.8	5.4	14.6	6.0
EKE 81	25.9	4.9	24.5	5.3	23.1	5.9	21.8	6.5	20.5	7.3
EKE 101	28.6	5.7	27.1	6.3	25.5	7.0	24.1	7.8	22.7	8.7
EKE 121	34.7	6.6	32.8	7.2	31.0	8.0	29.2	8.9	27.5	9.9
EKE 151	37.0	7.2	35.0	7.9	33.1	8.8	31.2	9.7	29.3	10.8
EKE 201	55.0	10.1	51.0	10.9	47.2	11.9	43.5	12.9	39.9	14.1
EKE 252	59.7	11.6	56.5	12.8	53.4	14.2	50.3	15.8	47.3	17.5
EKE 302	75.7	14.5	71.6	16.0	67.6	17.7	63.7	19.6	60.0	21.9
EKE 352	91.9	16.6	86.7	18.0	81.7	19.7	76.7	21.6	72.0	23.7
EKE 402	108.4	18.7	100.6	20.2	93.1	21.9	85.8	23.8	79.0	26.0
EKE 502	119.0	22.0	113.0	24.3	106.5	26.8	99.6	29.7	92.5	32.8
EKE 602	132.9	23.0	126.7	25.3	119.8	27.9	112.5	30.8	104.9	34.0
EKE 702	165.3	29.9	157.8	32.9	149.6	36.2	140.7	39.9	131.3	44.0
EKE 804	225.9	40.1	209.6	43.4	193.7	47.1	178.5	51.3	164.1	56.0
EKE 1004	259.5	46.9	247.3	51.7	234.0	57.0	219.7	63.0	204.9	69.6
EKE 1204	303.7	53.2	290.4	58.7	275.7	64.7	259.8	71.5	242.7	79.1
EKE 1404	336.5	61.0	321.7	67.2	305.5	74.0	287.7	81.6	268.8	90.2

Model	Water 13/8 air 20°C		Water 13/8 air 25°C		Water 13/8 air 30°C		Water 13/8 air 35°C		Water 13/8 air 40°C	
	Cc	Pi	Cc	Pi	Cc	Pi	Cc	Pi	Cc	Pi
EKE 21	10.9	2.4	10.2	2.6	9.5	2.8	8.8	3.1	8.2	3.5
EKE 31	14.5	2.7	13.5	3.0	12.6	3.3	11.7	3.7	10.8	4.1
EKE 51	20.1	4.0	18.8	4.4	17.5	4.9	16.2	5.4	15.0	6.0
EKE 81	26.6	4.9	25.1	5.3	23.7	5.9	22.4	6.6	21.1	7.3
EKE 101	29.4	5.8	27.8	6.3	26.2	7.0	24.7	7.8	23.3	8.7
EKE 121	35.6	6.6	33.7	7.2	31.8	8.0	30.0	8.9	28.3	9.9
EKE 151	38.0	7.2	35.9	7.9	33.9	8.8	32.0	9.8	30.1	10.9
EKE 201	56.3	10.2	52.3	11.0	48.4	12.0	44.6	13.0	41.0	14.2
EKE 252	61.3	11.7	58.0	12.9	54.8	14.3	51.6	15.9	48.6	17.7
EKE 302	77.7	14.6	73.5	16.1	69.4	17.8	65.4	19.8	61.6	22.0
EKE 352	94.2	16.7	88.9	18.2	83.8	19.9	78.8	21.7	74.0	23.8
EKE 402	110.9	18.8	103.1	20.3	95.4	22.1	88.1	24.0	81.1	26.2
EKE 502	122.0	22.2	115.8	24.5	109.2	27.1	102.1	29.9	94.9	33.1
EKE 602	136.4	23.2	129.9	25.5	122.9	28.1	115.4	31.0	107.7	34.2
EKE 702	169.4	30.1	161.8	33.1	153.4	36.4	144.3	40.1	134.8	44.3
EKE 804	231.2	40.4	214.7	43.7	198.7	47.4	183.3	51.6	168.6	56.4
EKE 1004	266.3	47.3	253.8	52.1	240.2	57.4	225.5	63.4	210.3	70.1
EKE 1204	311.7	53.6	298.0	59.1	283.0	65.1	266.7	71.9	249.2	79.5
EKE 1404	345.1	61.4	330.0	67.7	313.4	74.5	295.2	82.1	276.0	90.7



Euroklimat has developed an online software called "wEKool" that allows you to select the chiller model closest to the project conditions.

For more information, please contact your sales representative.

EKE

Performance tables by temperature conditions

Model	Water 14/9 air 20°C		Water 14/9 air 25°C		Water 14/9 air 30°C		Water 14/9 air 35°C		Water 14/9 air 40°C	
	Cc	Pi	Cc	Pi	Cc	Pi	Cc	Pi	Cc	Pi
EKE 21	11.2	2.4	10.5	2.6	9.8	2.9	9.1	3.2	8.4	3.5
EKE 31	14.9	2.8	13.9	3.0	13.0	3.3	12.0	3.7	11.1	4.1
EKE 51	20.6	4.1	19.3	4.5	17.9	4.9	16.6	5.5	15.4	6.1
EKE 81	27.3	4.9	25.8	5.4	24.4	5.9	23.0	6.6	21.6	7.4
EKE 101	30.1	5.8	28.5	6.4	26.9	7.1	25.4	7.9	23.9	8.8
EKE 121	36.6	6.6	34.6	7.3	32.7	8.1	30.8	9.0	29.0	10.0
EKE 151	39.0	7.2	36.9	8.0	34.8	8.9	32.8	9.9	30.9	11.0
EKE 201	57.6	10.3	53.5	11.1	49.6	12.1	45.8	13.1	42.2	14.3
EKE 252	62.9	11.7	59.5	13.0	56.2	14.4	53.0	16.0	49.9	17.8
EKE 302	79.7	14.6	75.5	16.2	71.3	17.9	67.2	19.9	63.2	22.2
EKE 352	96.5	16.9	91.1	18.4	85.9	20.0	80.8	21.9	76.0	24.0
EKE 402	113.5	19.0	105.6	20.5	97.8	22.2	90.4	24.2	83.3	26.4
EKE 502	125.1	22.5	118.7	24.7	111.9	27.3	104.7	30.1	97.3	33.3
EKE 602	139.9	23.4	133.3	25.7	126.1	28.3	118.4	31.2	110.5	34.5
EKE 702	173.6	30.3	165.9	33.4	157.3	36.7	147.9	40.4	138.3	44.5
EKE 804	236.6	40.8	219.9	44.1	203.6	47.8	188.0	52.0	173.2	56.8
EKE 1004	273.2	47.7	260.3	52.5	246.4	57.9	231.3	63.9	215.9	70.6
EKE 1204	319.8	54.0	305.8	59.5	290.5	65.6	273.7	72.3	255.9	80.0
EKE 1404	353.7	61.9	338.4	68.1	321.4	75.0	302.9	82.6	283.2	91.2

Model	Water 15/10 air 20°C		Water 15/10 air 25°C		Water 15/10 air 30°C		Water 15/10 air 35°C		Water 15/10 air 40°C	
	Cc	Pi	Cc	Pi	Cc	Pi	Cc	Pi	Cc	Pi
EKE 21	11.5	2.4	10.8	2.6	10.1	2.9	9.4	3.2	8.7	3.5
EKE 31	15.3	2.8	14.3	3.1	13.3	3.4	12.4	3.7	11.5	4.1
EKE 51	21.2	4.1	19.8	4.5	18.4	5.0	17.1	5.5	15.8	6.1
EKE 81	28.0	4.9	26.5	5.4	25.0	6.0	23.6	6.6	22.2	7.4
EKE 101	30.9	5.8	29.3	6.4	27.6	7.1	26.0	7.9	24.5	8.8
EKE 121	37.6	6.6	35.5	7.3	33.6	8.1	31.6	9.0	29.8	10.1
EKE 151	40.0	7.3	37.9	8.1	35.7	8.9	33.7	9.9	31.7	11.1
EKE 201	58.9	10.4	54.8	11.2	50.8	12.2	47.0	13.2	43.3	14.4
EKE 252	64.5	11.8	61.1	13.1	57.7	14.5	54.4	16.1	51.2	17.9
EKE 302	81.8	14.7	77.4	16.3	73.1	18.0	68.9	20.1	64.9	22.3
EKE 352	98.8	17.1	93.4	18.5	88.1	20.2	83.0	22.1	78.0	24.2
EKE 402	116.1	19.2	108.1	20.7	100.2	22.4	92.7	24.4	85.5	26.6
EKE 502	128.1	22.7	121.6	25.0	114.6	27.5	107.3	30.4	99.8	33.6
EKE 602	143.4	23.6	136.6	26.0	129.3	28.6	121.4	31.5	113.4	34.7
EKE 702	177.9	30.6	169.9	33.6	161.2	36.9	151.6	40.6	141.9	44.8
EKE 804	242.1	41.1	225.2	44.4	208.7	48.2	192.9	52.5	177.8	57.2
EKE 1004	280.1	48.2	267.0	53.0	252.7	58.4	237.2	64.4	221.6	71.1
EKE 1204	327.9	54.4	313.6	59.9	298.0	66.0	280.9	72.8	262.7	80.4
EKE 1404	362.5	62.3	346.9	68.6	329.5	75.5	310.6	83.1	290.6	91.7



Euroklimat has developed an online software called "wEKool" that allows you to select the chiller model closest to the project conditions.

For more information, please contact your sales representative.

Performance tables by temperature conditions

Model	Water 17/12 air 20°C		Water 17/12 air 25°C		Water 17/12 air 30°C		Water 17/12 air 35°C		Water 17/12 air 40°C	
	Cc	Pi	Cc	Pi	Cc	Pi	Cc	Pi	Cc	Pi
EKE 21	12.2	2.4	11.4	2.6	10.7	2.9	9.9	3.2	9.2	3.6
EKE 31	16.2	2.8	15.1	3.1	14.1	3.4	13.1	3.8	12.1	4.2
EKE 51	22.3	4.2	20.8	4.6	19.4	5.1	18.0	5.6	16.7	6.2
EKE 81	29.5	4.9	27.9	5.5	26.4	6.0	24.9	6.7	23.4	7.5
EKE 101	32.5	5.9	30.8	6.5	29.1	7.2	27.4	8.0	25.8	9.0
EKE 121	39.5	6.7	37.4	7.4	35.4	8.2	33.3	9.2	31.4	10.2
EKE 151	42.1	7.4	39.8	8.2	37.6	9.1	35.5	10.1	33.4	11.2
EKE 201	61.6	10.6	57.4	11.4	53.3	12.4	49.3	13.5	45.6	14.7
EKE 252	67.9	12.0	64.3	13.3	60.7	14.7	57.2	16.3	53.8	18.2
EKE 302	86.1	15.0	81.5	16.5	77.0	18.3	72.5	20.4	68.3	22.6
EKE 352	103.7	17.4	98.1	18.9	92.7	20.6	87.4	22.5	82.3	24.6
EKE 402	121.3	19.5	113.1	21.1	105.1	22.8	97.4	24.8	90.0	27.0
EKE 502	134.4	23.1	127.5	25.5	120.2	28.0	112.6	30.9	104.7	34.1
EKE 602	150.6	24.1	143.5	26.5	135.7	29.1	127.5	32.0	119.2	35.3
EKE 702	186.5	31.1	178.2	34.1	169.1	37.5	159.2	41.2	149.1	45.4
EKE 804	253.2	41.8	236.0	45.2	219.0	49.0	202.8	53.3	187.2	58.1
EKE 1004	294.4	49.1	280.5	54.0	265.5	59.4	249.4	65.4	233.0	72.2
EKE 1204	344.7	55.2	329.7	60.8	313.3	66.9	295.4	73.7	276.6	81.4
EKE 1404	380.5	63.2	364.1	69.5	346.0	76.5	326.3	84.1	305.7	92.8

Model	Water 20/15 air 20°C		Water 20/15 air 25°C		Water 20/15 air 30°C		Water 20/15 air 35°C		Water 20/15 air 40°C	
	Cc	Pi	Cc	Pi	Cc	Pi	Cc	Pi	Cc	Pi
EKE 21	13.2	2.5	12.4	2.7	11.6	3.0	10.8	3.3	10.0	3.7
EKE 31	17.5	2.9	16.4	3.2	15.3	3.5	14.2	3.9	13.2	4.3
EKE 51	23.9	4.3	22.4	4.7	20.9	5.2	19.4	5.8	18.0	6.4
EKE 81	31.9	5.0	30.2	5.6	28.5	6.2	26.9	6.9	25.3	7.6
EKE 101	35.1	6.1	33.2	6.7	31.4	7.4	29.6	8.2	27.8	9.1
EKE 121	42.7	6.9	40.4	7.6	38.2	8.4	36.0	9.4	33.9	10.4
EKE 151	45.3	7.6	42.9	8.4	40.5	9.3	38.2	10.3	35.9	11.5
EKE 201	65.8	10.9	61.4	11.7	57.1	12.7	53.0	13.8	49.0	15.0
EKE 252	73.1	12.4	69.2	13.6	65.4	15.1	61.6	16.7	58.0	18.6
EKE 302	92.7	15.4	87.8	17.0	83.0	18.8	78.2	20.8	73.6	23.1
EKE 352	111.3	18.0	105.5	19.5	99.8	21.2	94.3	23.1	89.0	25.2
EKE 402	129.4	20.1	120.9	21.7	112.6	23.4	104.5	25.5	96.8	27.7
EKE 502	143.9	23.9	136.5	26.2	128.7	28.8	120.7	31.8	112.3	35.0
EKE 602	161.8	24.9	154.0	27.2	145.7	29.9	137.0	32.9	128.0	36.2
EKE 702	199.9	31.9	191.0	35.0	181.3	38.3	170.9	42.1	160.1	46.3
EKE 804	270.4	43.0	252.4	46.4	234.8	50.3	217.8	54.6	201.5	59.5
EKE 1004	316.5	50.6	301.4	55.5	285.2	61.0	268.1	67.1	250.6	73.9
EKE 1204	370.6	56.6	354.6	62.2	336.9	68.3	317.8	75.2	298.0	82.9
EKE 1404	408.1	64.7	390.7	71.1	371.4	78.0	350.4	85.8	329.0	94.5



Euroklimat has developed an online software called "wEKool" that allows you to select the chiller model closest to the project conditions.

For more information, please contact your sales representative.

EKE

Standard Electronic Controller

EKE range is managed, by parametric electronic controllers specifically designed for process chillers.



This compact microprocessor can manage up to four hermetic scroll compressors with a maximum of two circuits, as well as controlling an electronic expansion valve in each circuit.

With the large number of inputs and outputs it has been developed in order to perfectly control EKE air/water chillers. The microprocessor has been designed with RISC technology and optional real time clock, ensuring top-of-the-range performance and user friendliness.

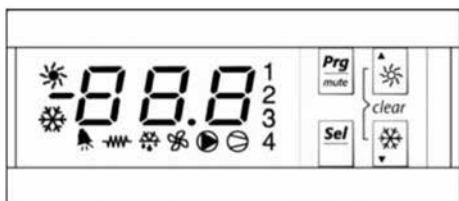

The front panel contains the display and keyboard, made up from 4 keys, which, pressed individually or together, allow to perform all of the controller programming operations.

The display features 3 digits, with the display of the decimal point between -99.9 and 99.9. Outside of this range of measurement, the value is automatically displayed without the decimal (even if internally the unit still operates considering the decimal part).

EKE microprocessor offers a wide range of communication interfaces. All the controllers, are compatible with the CAREL protocol (PlantVisor) and Modbus® RTU, for third party BMS systems.

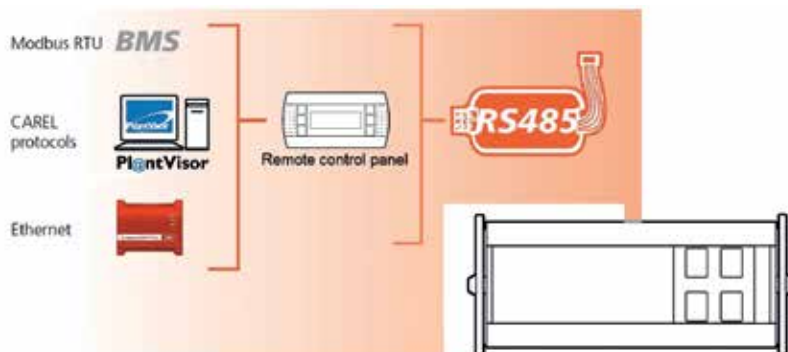

Remote monitoring services tERA



tERA: connectivity, monitoring and remote management systems remote control services.

tERA is the new platform ready to quickly bring the business to the sale of services. Now you can create a centralized remote management system to access quickly and easily all the necessary information.

tERA combines different technological platforms to ensure a cutting-edge solution: mobile connectivity, cloud computing and remote-control SW are integrated into one immediately accessible service.

Retrieve all the information you need at a simple click: you can solve minor configuration problems directly from your office, wherever you are. For more serious problems, fast data analysis gives you all the information you need before taking action and lets you know what components you have to take with you to restore correct system operation. For structural problems, you can connect via remote and upgrade the unit's control SW.



tService is the service of the **tERA** platform dedicated to the service centre. **tService** makes maintenance faster and more efficient with a solution ready for remote control.

Functions available are: reading and writing of variables in real time, history with frequencies up to 5", alarm management with notification via e-mail, reports and graphs up to 300 variables, live-trend, SW programmable controls update.

Connectivity to your system is simple and immediate. You can freely choose which communication channel to use during installation: the platform can either use Wireless GSM or an Ethernet line, with secure and reliable solutions. You can access all system information from any device: from your PC in the office, or smartphone or tablet wherever you're working offsite.

GSM solution

If it's hard to connect to the site's network, you can use a channel that works independently from the local infrastructure.

The **tERA** Wireless GSM lets you access your system using a pre-configured solution through registration on the **tERA** website in just a few clicks. Data are transmitted over a secure and reliable line: Machine2Machine connectivity (M2M) is available via a protected private channel (VPN).

Ethernet solution

If your site's network is accessible or local mobile phone is not reliable, you can choose the **tERA** Ethernet subscription.

The installation box is already configured to automatically connect to your system's router. No configuration of static IPs or router parameter settings are required to activate your subscription. With advanced SSL encryption SW, access to your data is secure and fast.

EKE

Advanced Electronic Controller

Thanks to a Multitasking Operating System and to the adoption of standard protocols, local and remote connectivity the controller used in EKE is the most advanced technology available.



NEW OPERATING SYSTEM

New Multitasking Operating System ensures optimal system resource usage, extended datatypes for user application (32bit floating point numbers) application speed increase and independent protocol engines.



CONNECTIVITY

The controller has two integrated Ethernet interfaces, three serial interfaces and two USB ports.

A great choice of communication protocols is possible (Modbus, Carel, BACnet, LON, Konnex, TCP/IP, HTTP, FTP, DHCP, DNS, NTP, SNMP and many others).



CLOUD SERVICE

Plug & Play solution for tERA platform connection. All tERA services are available just connecting the Ethernet plug to your home or office network, without the need for an external connection box.

Advanced Electronic Controller

The application software “**ekapt**” developed for **EKE** chillers allows an easy access to the machine configuration and management parameters with the menu system organised by device. There are three password levels to allow three different access modes to the parameters (read only for assistance, edit for servicing, total access for the manufacturer). The main screen gives quick access to the user functions without a password (information on the status of the machine components, On-Off and machine operating mode, set points).

PID control

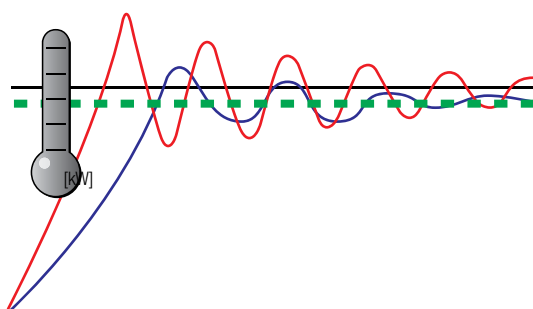

There are two types of PID control:

- PID control on start-up
- PID control during operation

The start-up control must prevent an excess of requested power.

Since at start-up the status of the load is not known but only the temperature is, the power must be entered little by little, waiting for the reaction of the system.

The control during operation must be quick in order to follow any load variations and maintain the water temperature as close to the set-point value as possible.

Compressor's envelope management

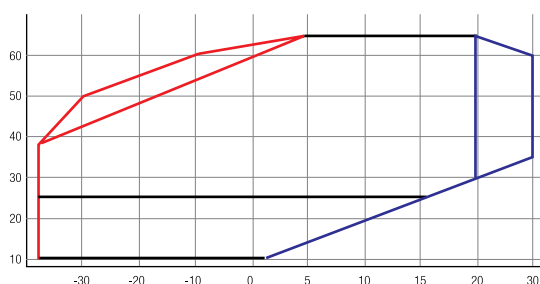

The operating limits (hereafter defined as envelope) of the compressors are controlled.

This control cannot be disabled in order to prevent the compressor from working outside of the safety limits dictated by the manufacturer. All of the compressors inserted thus contain the envelope data. When the operating condition is outside of the envelope, the alarm delay starts counting: if the operating condition remains outside of the envelope when the delay has elapsed, a specific alarm is activated, which stops the compressor; if, on the other hand, the operating condition returns within the envelope limits, the alarm delay counter is reset.

Compressors power distribution



“**ekapt**” application software provides management of the power distributed to the compressors in the best way possible to increase the efficiency of the unit.

The behaviour of power distribution changes depending on the configuration, 1 or 2 circuits and the power ratio between compressors. In the event of an alarm for one compressor, the next available compressor will be turned on as a replacement if the request is high enough. For units with two circuits and prevention active in one circuit, the rotation will compensate for the limited circuit by increasing the request on the available circuit.

Web commissioning tool



Through internet browser, inserting the IP address of the control card, it will be possible to access the “**ekapt**” application in order to see and edit service parameters.

The application is divided in:

Main: in which are shown the main status parameter of the unit.

Synoptic: main unit parameters, according to the circuit number and Unit live trend available.

Parameters: it is necessary to be logged-in to open the Parameter menu. It is necessary to be, at least, Service user to be able to edit all the parameters.

Alarms List: alarms list, with start and end period of the alarm.

EKE

Sound levels

Sound levels are obtained by means of theoretical calculations that could deviate from the real conditions of the place of installation of the unit.

Sound Power: this is the acoustic emission of the unit when operating. It is dependent on operating conditions. Sound power level in compliance with ISO 3744.

Sound Pressure: this is the measurement of the effect of the acoustic emission generated by the unit at a certain distance and in the acoustic environment (reflection, absorption, directivity) in which it operates. The value will depend on the sound power of the unit, the directivity of the source and the reflectivity of the surroundings. Sound pressure level (average value), calculated for unit in a free field on a reflective surface; non-binding value obtained from the sound power level.

It is assumed that sound power and sound pressure are linked together by defining the space and conditions as follows:

- » the source is omnidirectional, i.e. the acoustic emission is the same in all directions
- » the conditions are free field, i.e. at 1 meter from the source there is no effect from acoustic wave reflections with the exception of the support plane

The power is therefore distributed over an imaginary sphere around the unit and the following relationship applies:

- » sound pressure at 1 m = sound power - 11 dB (A)



The below legend allows you to easily select the proper configuration of EKE chiller.

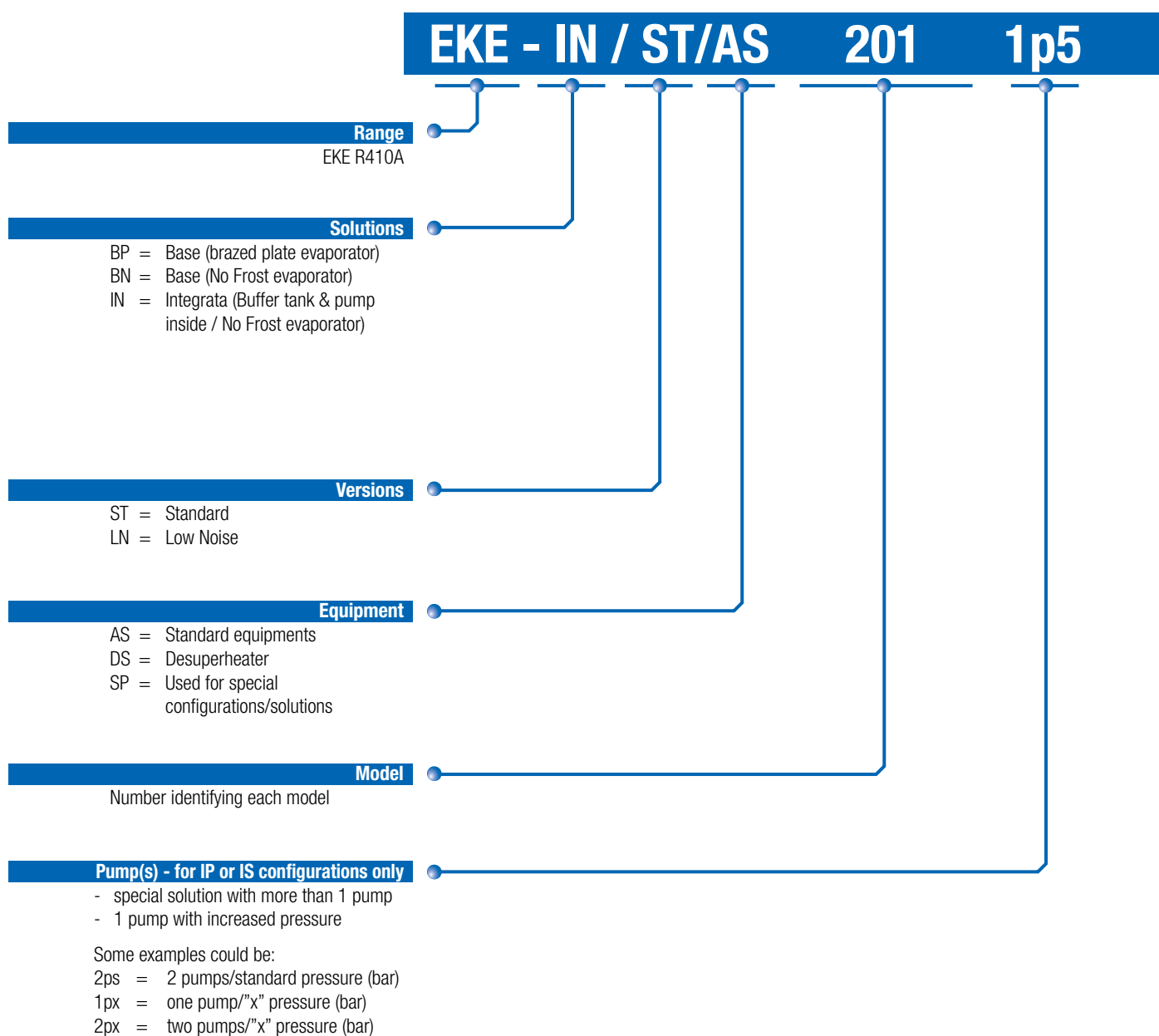

Some of the special "SP" configuration / solutions that Euroklimat offers are:

- EKE with shell and tube evaporator
- EKE with compressor(s) under inverter
- EKE with plug fan(s) for internal installation with ducted system

General

Power supply to the unit

EKE range is designed to be electrically powered with the following different tensions or frequencies:

- » Power supply 400V/3ph/50Hz (Standard)
- » Power supply 200V-220V-575V-600V/3ph/50-60Hz with autotransformer
- » Power supply 380V or 400V/3ph/60Hz with autotransformer
- » Power supply 440V-480V/3ph/60Hz with autotransformer
- » Power supply 460V/3ph/60Hz without autotransformer

Anti-vibration spring mounts (supplied separately)



Spring vibration isolation mounting (Kit). The system prevent the transmission of vibrations to the structure where the unit is located.

Condensing coil protection panel



Metal protection panel for condensing coil against accidental impacts.

Aluminum panels (fan panel not included)



Panels of the unit are made of aluminium, with the exception of fan(s) bellmouth, to reduce weight of the unit and to ensure higher weathering resistance.

Nylon wheels with rotating support



Unit equipped with rotating support wheels, made in nylon, for an easy handling.

Anti-vibration rubber mounts (supplied separately)



Rubber vibration isolation mounting (Kit). The system prevent the transmission of vibrations to the structure where the unit is located.

Anti-vibration seismic spring mounts (supplied separately)



Seismic vibration isolation mounting (Kit). The system prevent the transmission of vibrations to the structure where the unit is located.

Metallic filters for condensing coils



Metallic filters specially designed for condensing coils applications on industrial chillers, made of an aluminum sheet frame and micro-extruded aluminum mesh. These filters ensure very low pressure drops and their design allow to cover large suction surfaces.

Stainless steel panels (AISI 304) - (fan panel not included)



Panels of the unit are made of Stainless Steel (AISI 304), with the exception of fan(s) bellmouth, to ensure higher weathering resistance.

Standard equipment and Accessories

Condensing section

Cu/Al condensing coil with ElectroFin® treatment

ElectroFin® treatment delivers corrosion durability protection for fins and tubes, increasing efficiency and length of service.

Cu/Al condensing coil with Blygold® treatment

Condensing coil with copper tubes and aluminum fins. The Blygold® treatment provides a long lasting corrosion protection to heat exchangers, without affecting heat transfer and pressure drop. The heat conductive pigmentation in the coating is oriented in such a way that it creates a very high chemical resistance at a low layer thickness.

Condensing coil with Thermoguard treatment

Condensing coil with copper tubes and aluminum fins. The Thermoguard treatment is a polyurethane-based anticorrosive coating with high flexibility that protects the exchangers from the hostile conditions of corrosive environments, ensuring longer life of the unit. The product includes aluminum pigments that improve its thermal conductivity and resistance to UV rays. The purpose of the product is to provide protection and prevention against the chemical and galvanic corrosion of the heat exchangers.

On/Off condensing pressure control

Condensing pressure control by pressure switch that constantly reads condensing pressure. Setpoints are setted in order to switch on/switch off fans.

Cu/Al condensing coil with AiAX Coatings treatment

Condensing coil with copper tubes and aluminum fins. The AiAX Coatings treatment protects the exchangers from the hostile conditions of the most aggressive environments. The treatment is specially designed to resist thermal contractions and expansions, UV rays, it is dirt repellent, mechanically resistant and with very limited heat transfer losses. It has practically no effects on air side pressure drop.

Cu/Al condensing coil with Heresite P413 treatment

Condensing coil with copper tubes and aluminum fins. The Heresite P413 treatment is a thin film, high performance coating used for protecting heat exchangers. It is the first HVAC-R coil coating to meet the ISO 20340 Standard for severe offshore marine environments. The corrosion resistance of Heresite P413 coatings significantly extends the service life of heat exchangers. In addition to marine and salt air environments, the P413 coatings will withstand exposure to an extensive variety of high and low pH corrosive and chemical fumes and condensate.

Cu/Cu condensing coil

Condensing coil with copper tubes and copper fins, solution provided to increase heat exchange efficiency.

Phase-cut modulating fan speed controller - CPC

Modulating condensing control by regulation of fans speed using cutting phase system.

EKE

Standard equipment and Accessories

Refrigerant circuit section

Refrigerant leak detector



The unit is equipped with a special gas detector to monitor any refrigerant circuit leaks.

Compressor crankcase oil heater



Crankcase electric heater directly installed on the compressor in order to evaporate any drops of liquid present.

High & Low pressure manometers



Gauges for the control of low and high refrigerant pressures, embedded in glycerine.

Electronic expansion valve



Electronic expansion valve for the accurate and timely control of the superheater level, after evaporation and many others operative functions.

Electric cabinet section

Phase monitoring sequence relay



Sequence phases relay mounted directly inside the electrical box and with the function of stopping the unit in the case where the phase sequence is not correct.

Power factor correction capacitors for compressors



Power factor compressor capacitor to keep the value of the cosφ higher than 0,9.

Emergency power electronic expansion valve (Ultracap module)



Ultracap is a emergency power supply device for systems that use electronic expansion valves: this device ensures complete closing of the valves even when there are sudden mains power failures.

Anti-condensation heater with thermostat



Heater with the function to maintain the temperature inside the enclosure several degrees above the dew point.

Min./Max. voltage relay



Min and max power supply relays mounted directly inside the electrical box and with the function of stopping the unit in case the power supply voltage is outside the tolerance range.

Device for measuring the electric energy consumed (Energy meter)



Measuring instrument dedicated to the detection of the main electrical parameters and the consumption of the connected loads. Energy meter records consumption and allows for a complete and detailed analysis.

Control section

Remote control panel



Remote user terminal can be used to get all the readings and duplicate commands on a second display located at a distance and in more accessible site compared to the microprocessor on board the machine.

Clock card - Alarm history up to 25 events (data logger function)



Clock card: alarms memory up to 25 events which ensures the possibility to deeply analyze available data.

Standard equipment and Accessories

Water circuit section

Differential pressure switch



Differential pressure switch with function to control the failure or reduced water flow.

Automatic overpressure by-pass valve



Water circuit automatic overpressure by-pass valve.

Electronic water flow switch (supplied separately)



Electronic flow switch with function to control the failure or reduced water flow.

Air vent valve (automatic)



Automatic air vent valve for discharging air from water circuit.

Non-ferrous water circuit



Water circuit made entirely from non-ferrous material.

Double water pump (stand-by) - Standard pressure



Pumping group consisting of two centrifugal electric pumps, one in stand-by (peripheral for model 21), with standard pressure drops.

Closed expansion tank with automatic filling valve



Closed expansion vessel for the containment of pressure variations in the water circuit. The fluid is separated from the gas chamber by a diaphragm and the tank is equipped with an automatic filling valve.

Pressure relief valve (4,5 bar setting)



Pressure relief valve for hydraulic circuit (4,5 bar setting).

Electromechanical water flow switch (supplied separately)



Electromechanical flow switch with function to control the failure or reduced water flow.

Air vent valve (manual)



Manual air vent valve for discharging air from water circuit.

Sacrificial anode installed inside the unit



Sacrificial anode installed inside the unit, with the cathodic protection function of the evaporator, preventing and avoiding its corrosion.

High pressure water pump (increased pump pressure)



Pumping group consisting of high head centrifugal electric pump (peripheral for models 21 and 31), suitable for water circuits with high pressure drops.

Open expansion tank



Open expansion vessel for the containment of pressure variations in the water circuit. The fluid is in direct contact with the atmosphere.

EKE	21 ÷ 51	81 ÷ 151	201 ÷ 252	302 ÷ 402	502 ÷ 702	804 ÷ 1404
General						
Low noise version: panels lined with sound absorbing material	○	○	○	○	○	○
Power supply 200-220-575-600V/3ph/50-60Hz with autotransformer	○	○	○	○	○	○
Power supply 380V or 400V/3ph/60Hz with autotransformer	○	○	○	○	○	○
Power supply 440-480V/3ph/60Hz with autotransformer	○	○	○	○	○	○
Power supply 460V/3ph/60Hz without autotransformer	○	○	○	○	○	○
Anti-vibration rubber mounts	○	○	○	-	-	-
Anti-vibration spring mounts	-	-	-	○	○	○
Anti-vibration seismic spring mounts	-	-	-	○	○	○
Condensing coil protection panel	○	○	○	○	○	-
Condensing coil protection grid	-	-	-	-	-	○
Condensing coil filter in aluminum mesh (single-mesh filter)	○	○	○	○	○	○
Condensing coil filter in micro-stretched aluminum mesh	○	○	○	○	○	○
Aluminum panels (fan panel not included)	○	○	○	○	○	○
Stainless steel (AISI 304) panels (fan panel not included)	○	○	○	○	○	○
Nylon wheels with rotating support	○	-	-	-	-	-
Wooden cage packing without base	○	○	○	○	○	-
Standard packing with wooden base	○	-	-	-	-	-
Condensing section						
Condensing coil in copper and turbulent aluminum fins	●	●	●	●	●	●
Condensing coil with ElectroFin® treatment	○	○	○	○	○	○
Condensing coil with AiAX Coatings treatment	○	○	○	○	○	○
Condensing coil with Blygold® treatment	○	○	○	○	○	○
Condensing coil with Heresite P413 treatment	○	○	○	○	○	○
Condensing coil with Thermoguard treatment	○	○	○	○	○	○
Condensing coil in copper/copper	○	○	○	○	○	○
On/Off condensing pressure control (step)	○	○	○	○	○	○
Phase-cut modulating fan speed controller - CPC	-	○	○	○	○	○
EC Fans (brushless motor)	○	○	○	○	○	○
Refrigerant circuit section						
Compliance with PED Directive (2014/68/EU)	●	●	●	●	●	●
Low pressure safety switch	●	●	●	●	●	●
High pressure safety switch	●	●	●	●	●	●
Refrigerant leak detector	○	○	○	○	○	○
High & Low pressure gauges	○	○	○	○	○	○
Compressor crankcase oil heater	○	○	○	○	○	○
Compressor suction and discharge valve	○	○	○	○	○	○
Electronic expansion valve	-	○	(1)	●	●	●
Oil level management with equalizer tube	-	-	(2)	●	●	●

(1) Available for model 201, standard for model 252

(2) Available only for model 252 as standard

(3) Included with option Advanced electronic controller

(4) Available with option Advanced electronic controller only

Standard equipment and Accessories

EKE	21 ÷ 51	81 ÷ 151	201 ÷ 252	302 ÷ 402	502 ÷ 702	804 ÷ 1404
Water circuit section						
Differential pressure switch	●	●	●	●	●	●
Pressure relief valve (4,5 bar setting)	●	●	●	●	●	●
Overpressure valve / automatic by-pass	○	○	○	○	○	-
Electromechanical water flow switch (supplied separately)	○	○	○	○	○	○
Electronic water flow switch (supplied separately)	○	○	○	○	○	○
Air vent valve (manual)	●	●	●	●	●	●
Air vent valve (automatic)	○	○	○	○	○	○
Thermal insulation - thickness 9 mm	●	●	●	●	●	●
Water filter (supplied separately)	○	○	○	○	○	○
Water pipes with trace heating	○	○	○	○	○	○
Flange for water fittings (carbon steel A105 or AISI 304L, PN 6)	○	○	○	○	○	○
Flange and counterflange for water fittings (carbon steel A105 or AISI 304L, PN 6)	○	○	○	○	○	○
Sacrificial anode installed inside the unit	○	○	○	○	○	○
Non-ferrous water circuit	○	○	○	○	○	○
High pressure water pump (5 bar)	○	○	○	○	○	○
Double water pump (stand-by) - Standard pressure	-	-	-	○	○	○
Open expansion tank	○	○	○	○	○	-
Closed expansion vessel with automatic filling unit	○	○	○	○	○	○
Electric cabinet section						
Power supply without neutral	●	●	●	●	●	●
Phase monitoring sequence relay	●	●	●	●	●	●
Anti-condensation heater with thermostat	-	○	○	○	○	○
Power factor correction capacitors for compressors	-	○	○	○	○	○
Min./max. voltage relay	○	○	○	○	○	○
Compressors soft-starter	○	○	○	○	○	○
Emergency power electronic expansion valve (Ultracap module)	-	○	○	○	○	○
Device for measuring the electric energy consumed (Energy Meter)	-	○	○	○	○	○
Control section						
Integrated Electronic Security module on-board compressor	-	-	-	-	●	●
Display with 3 digits and digital point	●	●	●	●	●	●
Remote control panel	○	○	○	○	○	○
Operating hour meter (Compressor, water pump)	●	●	●	●	●	●
Clock board and alarm history up to 25 events (data logger function)	○	○	○	○	○	○
Advanced electronic controller (c.pCO)	-	○	○	○	○	○
Second set-point from digital input	○	○	○	○	○	○
Remote On/Off digital input	●	●	●	●	●	●
Set point compensation by outside temperature	○	○	○	○	○	○
ModBus® interface RS 485 (3)	○	○	○	○	○	○
LonWorks® interface RS 485 (4)	-	○	○	○	○	○
BACnet® MS/TP interface (4)	-	○	○	○	○	○
BACnet® TCP/IP interface (4)	-	○	○	○	○	○
Software updates via USB key (4)	-	●	●	●	●	●
Update with transferring files via FTP (4)	-	○	○	○	○	○
Update via tERA cloud service (4)	○	○	○	○	○	○

● standard equipment ○ optional - not available

EKE		21	31	51	81	101	121	151	201
Power supply	-	400V/3ph/50Hz							
Control Power supply	-	24V-1ph-50Hz / 230V-1ph-50Hz							
BASE Solution (without pump) - AC fans									
Maximum absorbed power without pump	[kW]	4,7	5,5	7,7	10,1	11,6	13,3	14,5	18,4
Locked rotor current – LRA without pump	[A]	48,5	66,9	73,9	101,6	101,6	101,7	101,7	162,3
Maximum absorbed current (full load)	[A]	11,3	13,3	18,3	24,2	27,3	30,8	33,2	44,2
INTEGRATA Solution (Standard pump) - AC fans									
Maximum absorbed power with pump	[kW]	5,3	6,1	8,2	11,0	13,1	14,8	16,0	19,9
Locked rotor current – LRA with pump	[A]	50,6	68,9	75,9	104,1	105,7	105,8	105,8	166,4
Maximum absorbed current (full load)	[A]	13,4	15,3	20,3	26,7	31,4	34,9	37,3	48,3
INTEGRATA Solution (Increased pump) - AC fans									
Maximum absorbed power with pump	[kW]	5,8	6,6	8,6	11,4	12,9	15,5	16,7	20,6
Locked rotor current – LRA with pump	[A]	51,8	70,2	76,4	104,9	104,9	106,4	106,4	167,0
Maximum absorbed current (full load)	[A]	14,6	16,6	20,8	27,5	30,6	35,5	37,9	48,9
BASE Solution (without pump) - EC fans									
Maximum absorbed power without pump	[kW]	4,7	5,5	7,7	10,1	11,6	13,2	14,5	18,4
Locked rotor current – LRA without pump	[A]	48,3	66,7	73,7	101,2	101,2	101,2	101,2	161,4
Maximum absorbed current (full load)	[A]	11,1	13,0	18,1	23,7	26,9	30,3	32,7	43,3
INTEGRATA Solution (Standard pump) - EC fans									
Maximum absorbed power with pump	[kW]	5,3	6,1	8,2	11,0	13,1	14,7	16,0	19,9
Locked rotor current – LRA with pump	[A]	50,4	68,7	75,7	103,7	105,3	105,3	105,3	165,5
Maximum absorbed current (full load)	[A]	13,2	15,0	20,1	26,2	31,0	34,4	36,8	47,4
INTEGRATA Solution (Increased pump) - EC fans									
Maximum absorbed power with pump	[kW]	5,8	6,6	8,6	11,4	12,9	15,4	16,7	20,6
Locked rotor current – LRA with pump	[A]	51,6	70,0	76,2	104,5	104,5	105,9	105,9	166,1
Maximum absorbed current (full load)	[A]	14,4	16,3	20,6	27,0	30,2	35,0	37,4	48,0
Power supply									
Maximum cable section	[mm ²]	10	10	10	35	35	35	35	35

EKE		252	302	352	402	502	602	702
Power supply	-	400V/3ph/50Hz						
Control Power supply	-	24V-1ph-50Hz / 230V-1ph-50Hz						
BASE Solution (without pump) - AC fans								
Maximum absorbed power without pump	[kW]	23,3	29,9	32,8	37,5	40,3	47,9	59,7
Locked rotor current – LRA without pump	[A]	129,0	136,0	163,3	207,6	279,6	290,4	347,7
Maximum absorbed current (full load)	[A]	54,7	67,5	79,1	89,5	77,0	87,8	108,8
INTEGRATA Solution (Standard pump) - AC fans								
Maximum absorbed power with pump	[kW]	25,1	31,7	35,8	40,5	43,3	51,9	63,7
Locked rotor current – LRA with pump	[A]	133,7	140,7	169,7	214,0	286,0	299,1	356,4
Maximum absorbed current (full load)	[A]	59,4	72,2	85,5	95,9	83,4	96,5	117,5
INTEGRATA Solution (Increased pump) - AC fans								
Maximum absorbed power with pump	[kW]	25,5	33,9	38,3	43,0	47,8	55,4	67,2
Locked rotor current – LRA with pump	[A]	133,7	144,7	173,9	218,2	293,2	304,0	361,3
Maximum absorbed current (full load)	[A]	59,4	76,2	89,7	100,1	90,6	101,4	122,4
BASE Solution (without pump) - EC fans								
Maximum absorbed power without pump	[kW]	23,3	29,0	32,2	36,8	40,2	46,9	58,6
Locked rotor current – LRA without pump	[A]	128,1	133,8	160,2	204,4	278,2	285,7	342,9
Maximum absorbed current (full load)	[A]	53,8	65,3	76,0	86,3	75,6	83,1	104,0
INTEGRATA Solution (Standard pump) - EC fans								
Maximum absorbed power with pump	[kW]	25,1	30,8	35,2	39,8	43,2	50,9	62,6
Locked rotor current – LRA with pump	[A]	132,8	138,5	166,6	210,8	284,6	294,4	351,6
Maximum absorbed current (full load)	[A]	58,5	70,0	82,4	92,7	82,0	91,8	112,7
INTEGRATA Solution (Increased pump) - EC fans								
Maximum absorbed power with pump	[kW]	25,5	33,0	37,7	42,3	47,7	54,4	66,1
Locked rotor current – LRA with pump	[A]	132,8	142,5	170,8	215,0	291,8	299,3	356,5
Maximum absorbed current (full load)	[A]	58,5	74,0	86,6	96,9	89,2	96,7	117,6
Power supply								
Maximum cable section	[mm ²]	35	35	70	Lug terminals M8x25	Lug terminals M8x25	Lug terminals M8x25	Lug terminals M8x25

EKE		804	1004	1204	1404
Power supply	-	400V/3ph/50Hz			
Control Power supply	-	24V-1ph-50Hz / 230V-1ph-50Hz			
BASE Solution (without pump) - AC fans					
Maximum absorbed power without pump	[kW]	74,4	92,0	106,7	118,3
Locked rotor current – LRA without pump	[A]	296,2	370,2	434,3	455,1
Maximum absorbed current (full load)	[A]	178,1	167,6	195,4	216,2
INTEGRATA Solution (Standard pump) - AC fans					
Maximum absorbed power with pump	[kW]	79,9	97,5	114,2	125,8
Locked rotor current – LRA with pump	[A]	306,8	380,8	447,9	468,7
Maximum absorbed current (full load)	[A]	188,7	178,2	209,0	229,8
INTEGRATA Solution (Increased pump) - AC fans					
Maximum absorbed power with pump	[kW]	85,4	103,0	117,7	129,3
Locked rotor current – LRA with pump	[A]	317,5	391,5	455,6	476,4
Maximum absorbed current (full load)	[A]	199,4	188,9	216,7	237,5
BASE Solution (without pump) - EC fans					
Maximum absorbed power without pump	[kW]	73,3	90,8	104,9	116,5
Locked rotor current – LRA without pump	[A]	290,2	364,1	425,3	446,1
Maximum absorbed current (full load)	[A]	172,1	161,5	186,4	207,2
INTEGRATA Solution (Standard pump) - EC fans					
Maximum absorbed power with pump	[kW]	78,8	96,3	112,4	124,0
Locked rotor current – LRA with pump	[A]	300,8	374,7	438,9	459,7
Maximum absorbed current (full load)	[A]	182,7	172,1	200,0	220,8
INTEGRATA Solution (Increased pump) - EC fans					
Maximum absorbed power with pump	[kW]	84,3	101,8	115,9	127,5
Locked rotor current – LRA with pump	[A]	311,5	385,4	446,6	467,4
Maximum absorbed current (full load)	[A]	193,4	182,8	207,7	228,5
Power supply					
Maximum cable section	[mm ²]	Lug terminals M8x25	Lug terminals M8x25	Lug terminals M8x25	Lug terminals M8x25

Tolerance on the voltage $\pm 10\%$, tolerance on the frequency $\pm 2\%$

CUSTOMER INTERFACE

Remote On / Off

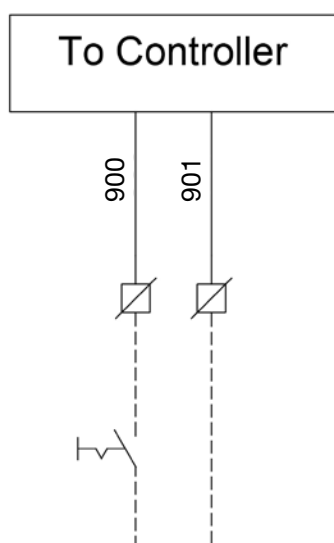

General Alarm

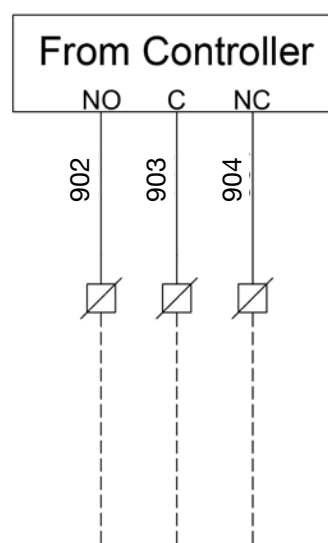

EKE

Dimensions and Operating spaces

EKE
21

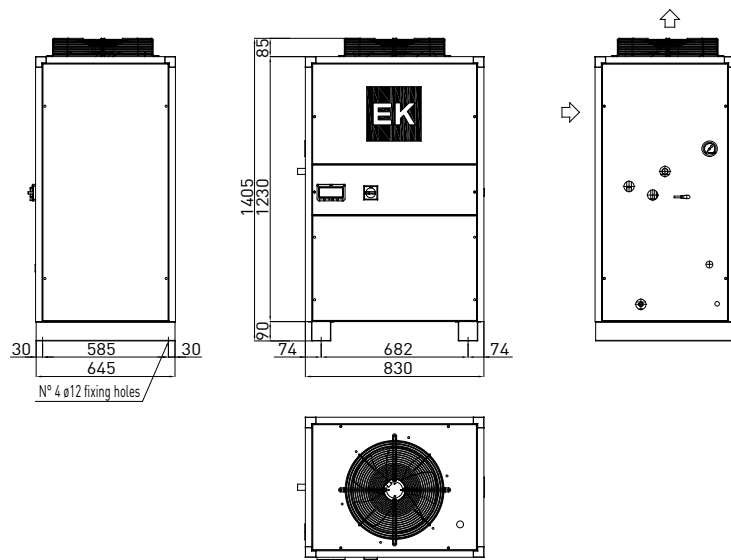

EKE range

21

Dimensions

Length	[mm]	830
Width	[mm]	645
Height (ST - LN)	[mm]	1.405

Weights

Weight BASE unit / BP (brazed plates evaporator)	[Kg]	185
Weight BASE unit / BP (brazed plates evaporator) / LN low noise	[Kg]	187
Shipping weight INTEGRATA unit / IN (No-Frost evaporator)	[Kg]	200
Working weight INTEGRATA unit / IN (No-Frost evaporator)	[Kg]	230
Shipping weight INTEGRATA unit / IN (No-Frost evaporator) / LN low noise	[Kg]	202
Working weight INTEGRATA unit / IN (No-Frost evaporator) / LN low noise	[Kg]	232

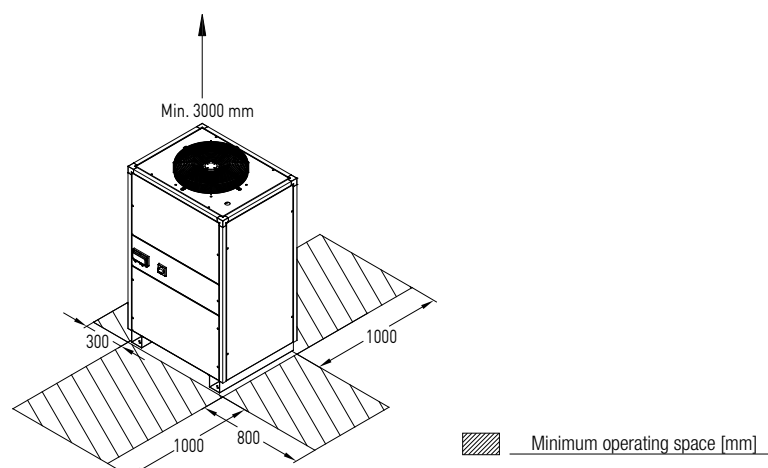

Dimensions and Operating spaces

EKE
31 ← → 51

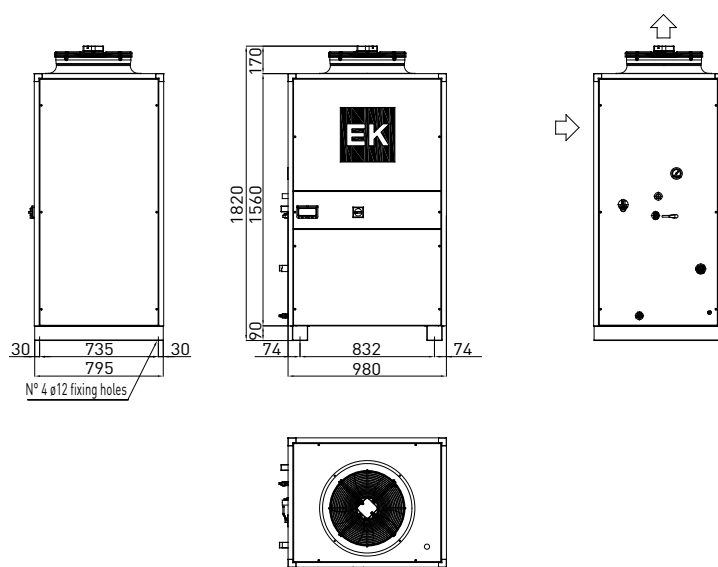

EKE range		31	51
Dimensions			
Length	[mm]	980	
Width	[mm]	795	
Height (ST - LN)	[mm]	1.820	
Weights			
Weight BASE unit / BP (brazed plates evaporator)	[Kg]	240	250
Weight BASE unit / BP (brazed plates evaporator) / LN low noise	[Kg]	243	253
Shipping weight INTEGRATA unit / IN (No-Frost evaporator)	[Kg]	265	275
Working weight INTEGRATA unit / IN (No-Frost evaporator)	[Kg]	325	335
Shipping weight INTEGRATA unit / IN (No-Frost evaporator) / LN low noise	[Kg]	268	278
Working weight INTEGRATA unit / IN (No-Frost evaporator) / LN low noise	[Kg]	328	338

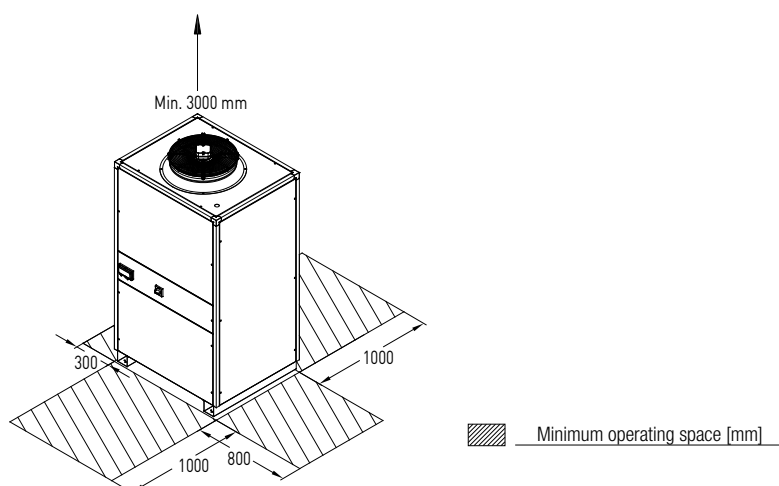

EKE

Dimensions and Operating spaces

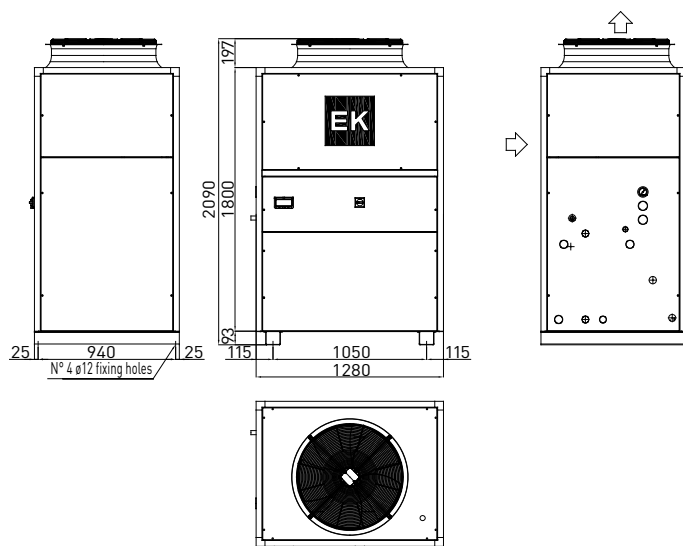

EKE range	81	101	121	151
-----------	----	-----	-----	-----

Dimensions					
Lenght	[mm]				1.280
Width	[mm]				990
Height (ST - LN)	[mm]				2.090

Weights					
Weigth BASE unit / BP (brazed plates evaporator)	[Kg]	400	415	420	430
Weigth BASE unit / BP (brazed plates evaporator) / LN low noise	[Kg]	404	419	424	434
Shipping weight INTEGRATA unit / IN (No-Frost evaporator)	[Kg]	460	480	485	495
Working weigth INTEGRATA unit / IN (No-Frost evaporator)	[Kg]	620	640	645	655
Shipping weight INTEGRATA unit / IN (No-Frost evaporator) / LN low noise	[Kg]	464	484	489	499
Working weigth INTEGRATA unit / IN (No-Frost evaporator) / LN low noise	[Kg]	624	644	649	659

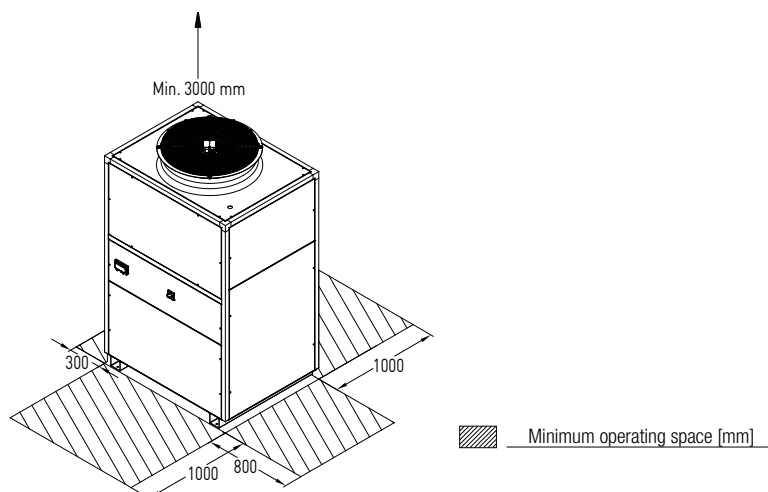

Dimensions and Operating spaces

EKE
201 ← → 252

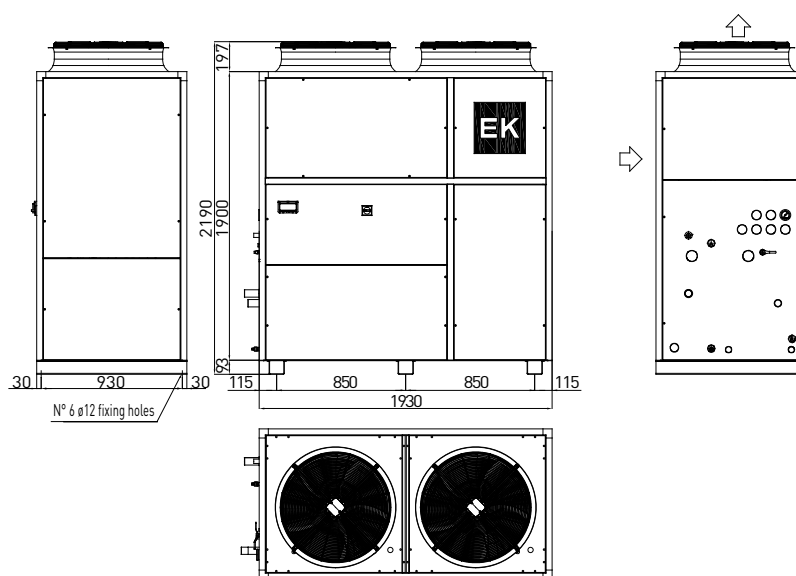

EKE range		201	252
Dimensions			
Length	[mm]	1.930	
Width	[mm]	990	
Height (ST - LN)	[mm]	2.190	
Weights			
Weight BASE unit / BP (brazed plates evaporator)	[Kg]	565	655
Weight BASE unit / BP (brazed plates evaporator) / LN low noise	[Kg]	570	660
Shipping weight INTEGRATA unit / IN (No-Frost evaporator)	[Kg]	660	750
Working weight INTEGRATA unit / IN (No-Frost evaporator)	[Kg]	950	1.040
Shipping weight INTEGRATA unit / IN (No-Frost evaporator) / LN low noise	[Kg]	665	755
Working weight INTEGRATA unit / IN (No-Frost evaporator) / LN low noise	[Kg]	955	1.045

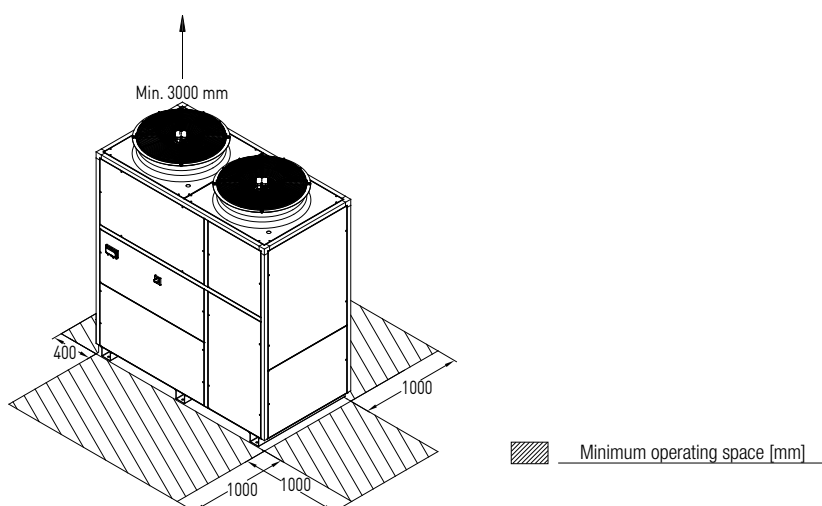

EKE

Dimensions and Operating spaces

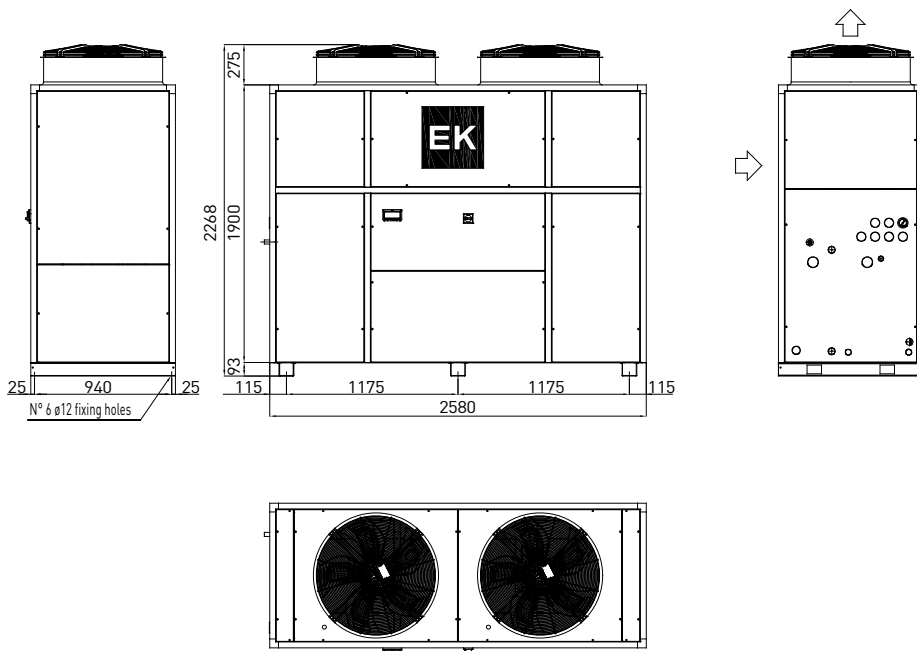

EKE range	302	352	402
-----------	-----	-----	-----

Dimensions			
Lenght	[mm]	2.580	
Width	[mm]	990	
Height (ST - LN)	[mm]	2.268	

Weights				
Weigth BASE unit / BP (brazed plates evaporator)	[Kg]	885	960	985
Weigth BASE unit / BP (brazed plates evaporator) / LN low noise	[Kg]	892	967	992
Shipping weigth INTEGRATA unit / IN (No-Frost evaporator)	[Kg]	995	1.100	1.120
Working weigth INTEGRATA unit / IN (No-Frost evaporator)	[Kg]	1.455	1.560	1.580
Shipping weigth INTEGRATA unit / IN (No-Frost evaporator) / LN low noise	[Kg]	1.002	1.107	1.127
Working weigth INTEGRATA unit / IN (No-Frost evaporator) / LN low noise	[Kg]	1.462	1.567	1.587

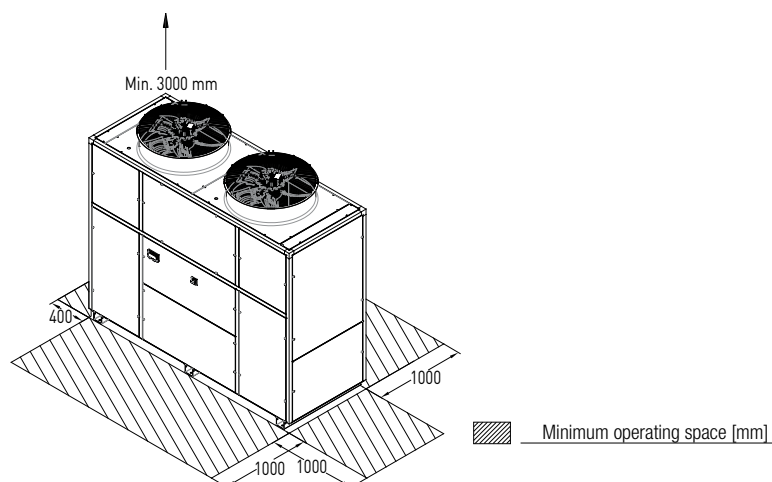

Dimensions and Operating spaces

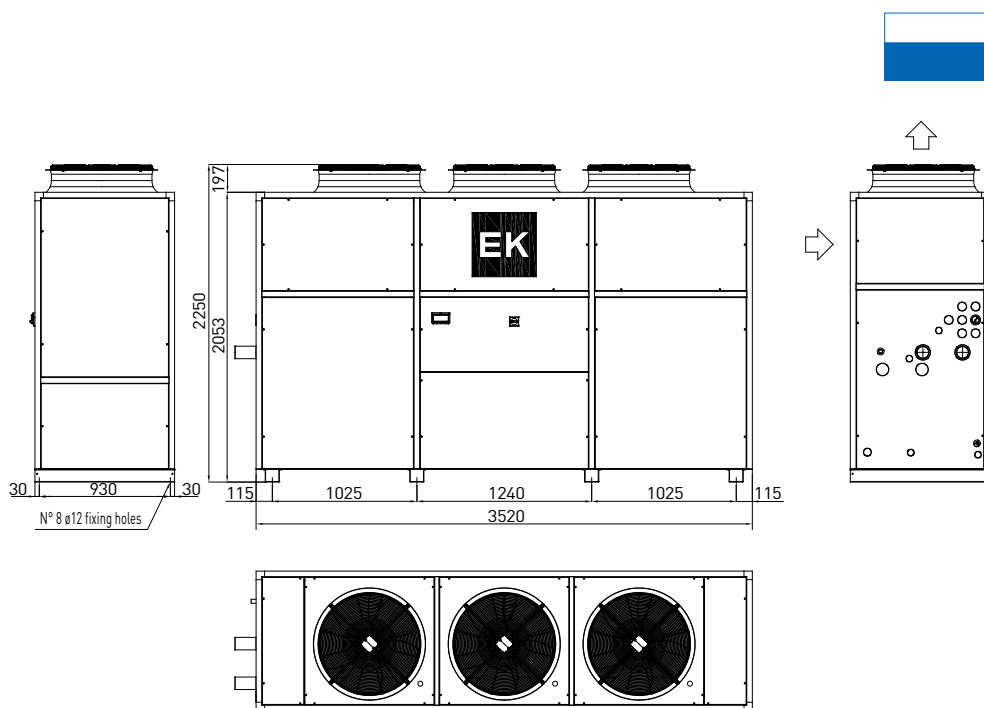

EKE range **502**

Dimensions		
Lenght	[mm]	3.520
Width	[mm]	990
Height (ST - LN)	[mm]	2.250

Weights		
Weigth BASE unit / BP (brazed plates evaporator)	[Kg]	1.140
Weigth BASE unit / BP (brazed plates evaporator) / LN low noise	[Kg]	1.150
Shipping weight INTEGRATA unit / IN (No-Frost evaporator)	[Kg]	1.320
Working weigth INTEGRATA unit / IN (No-Frost evaporator)	[Kg]	1.820
Shipping weight INTEGRATA unit / IN (No-Frost evaporator) / LN low noise	[Kg]	1.330
Working weigth INTEGRATA unit / IN (No-Frost evaporator) / LN low noise	[Kg]	1.830

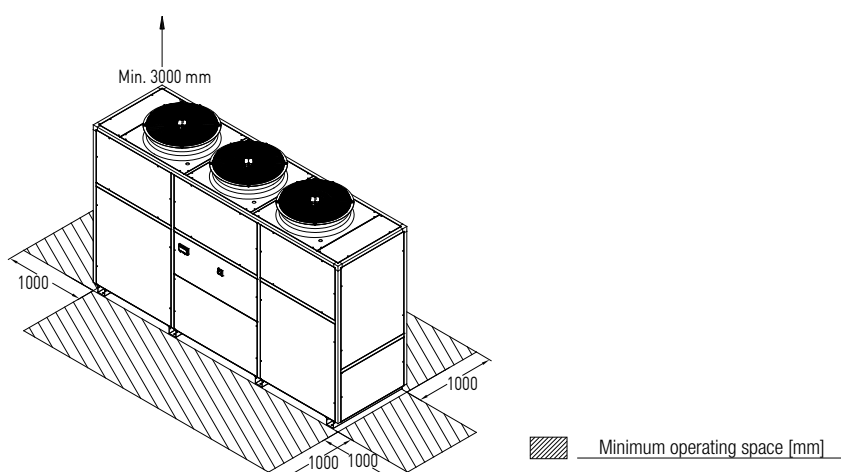

EKE

Dimensions and Operating spaces

EKE
602 ← → 702

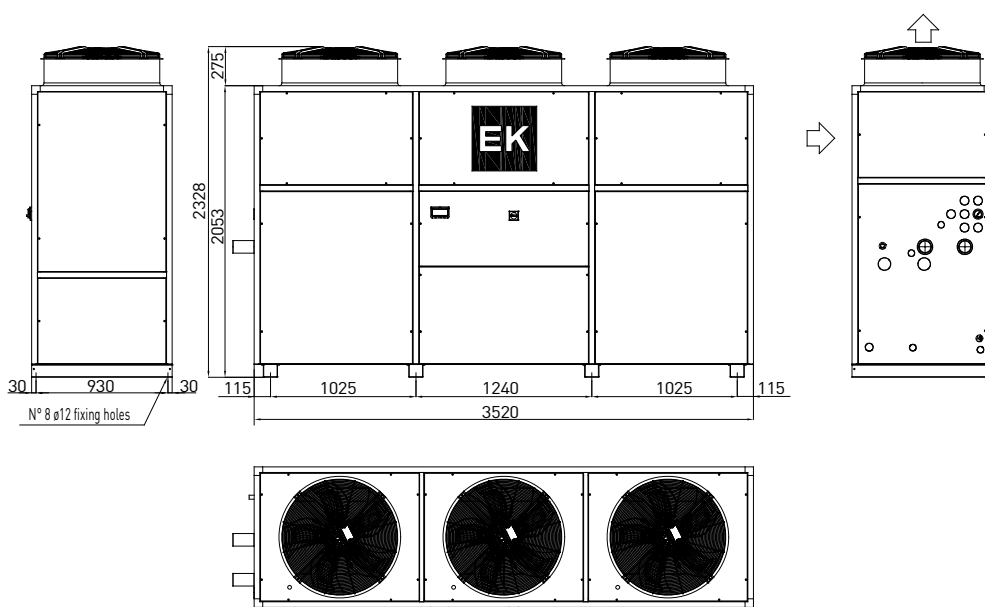

EKE range 602 702

Dimensions		602	702
Length	[mm]	3.520	
Width	[mm]	990	
Height (ST - LN)	[mm]	2.328	

Weights			
Weight BASE unit / BP (brazed plates evaporator)	[Kg]	1.200	1.220
Weight BASE unit / BP (brazed plates evaporator) / LN low noise	[Kg]	1.210	1.230
Shipping weight INTEGRATA unit / IN (No-Frost evaporator)	[Kg]	1.380	1.400
Working weight INTEGRATA unit / IN (No-Frost evaporator)	[Kg]	1.880	1.900
Shipping weight INTEGRATA unit / IN (No-Frost evaporator) / LN low noise	[Kg]	1.390	1.410
Working weight INTEGRATA unit / IN (No-Frost evaporator) / LN low noise	[Kg]	1.890	1.910

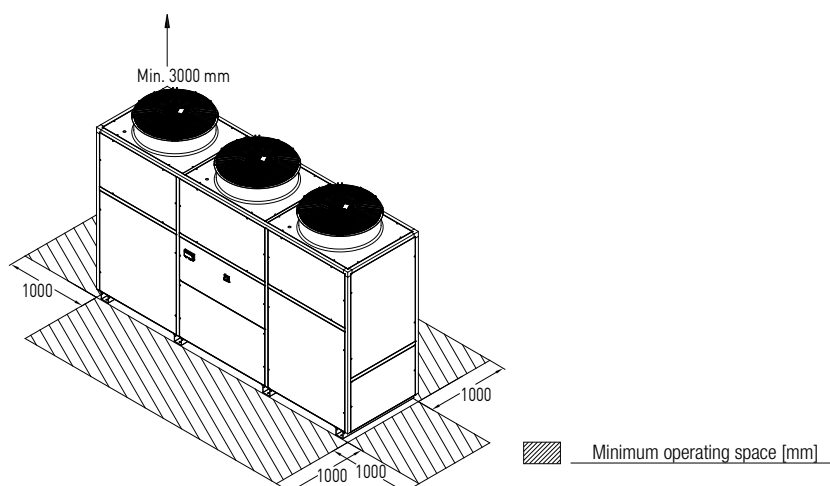

Dimensions and Operating spaces

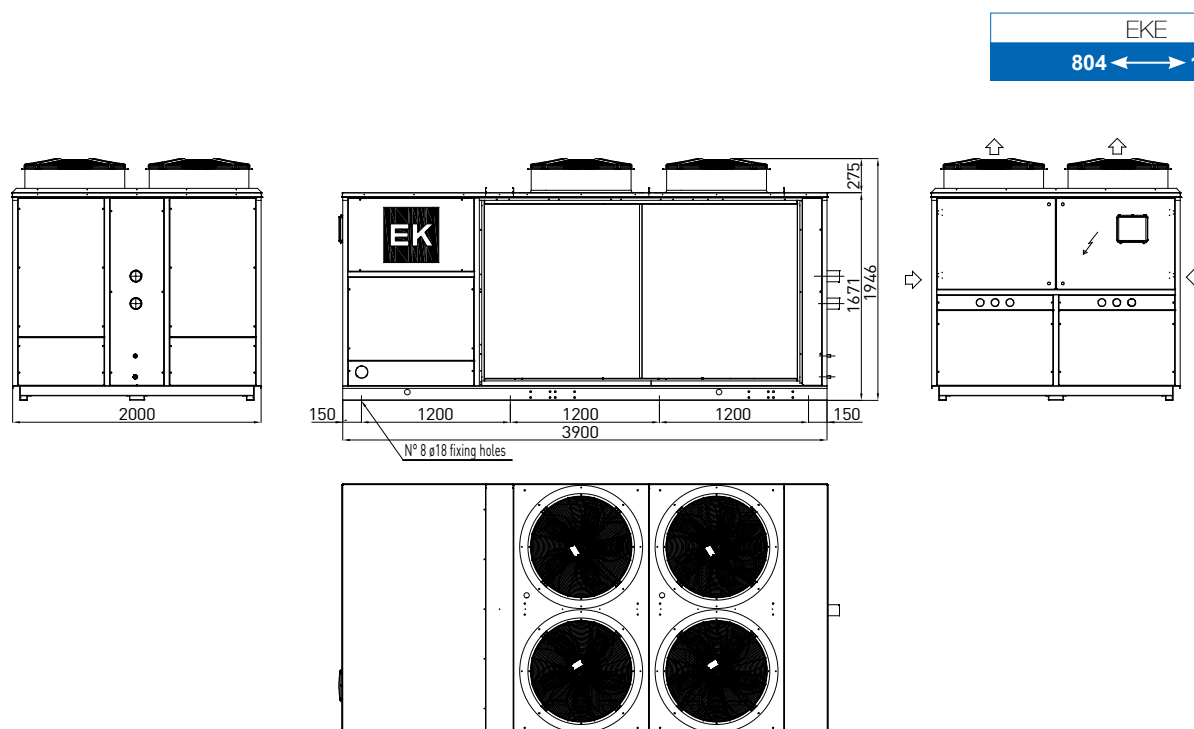

EKE range		1204	1404
Dimensions			
Length	[mm]	3.900	
Width	[mm]	2.000	
Height (ST - LN)	[mm]	1.946	
Weights			
Weight BASE unit / BP (brazed plates evaporator)	[Kg]	2.040	2.065
Weight BASE unit / BP (brazed plates evaporator) / LN low noise	[Kg]	2.048	2.073
Shipping weight INTEGRATA unit / IN (No-Frost evaporator)	[Kg]	2.280	2.300
Working weight INTEGRATA unit / IN (No-Frost evaporator)	[Kg]	3.200	3.220
Shipping weight INTEGRATA unit / IN (No-Frost evaporator) / LN low noise	[Kg]	2.288	2.308
Working weight INTEGRATA unit / IN (No-Frost evaporator) / LN low noise	[Kg]	3.208	3.228

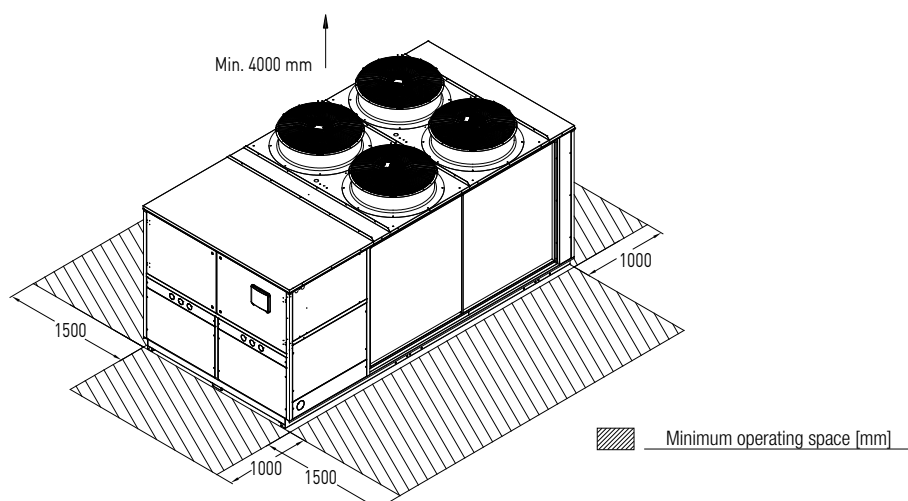

EKE

Dimensions and Operating spaces

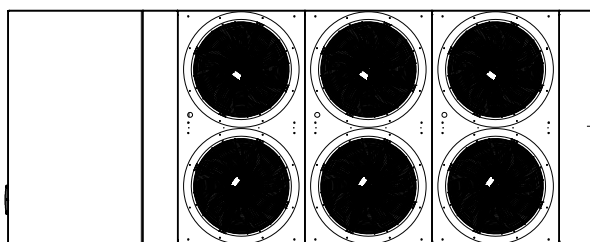
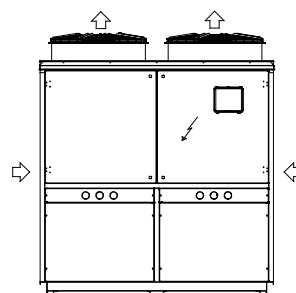
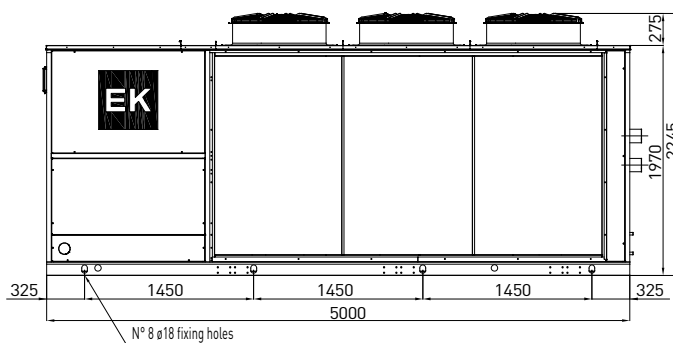
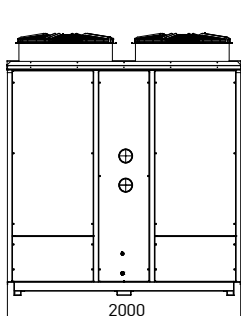

EKE range	1204	1404
-----------	------	------

Dimensions		
Lenght	[mm]	5.000
Width	[mm]	2.000
Height (ST - LN)	[mm]	2.245

Weights			
Weigth BASE unit / BP (brazed plates evaporator)	[Kg]	2.260	2.380
Weigth BASE unit / BP (brazed plates evaporator) / LN low noise	[Kg]	2.270	2.390
Shipping weight INTEGRATA unit / IN (No-Frost evaporator)	[Kg]	2.590	2.700
Working weigth INTEGRATA unit / IN (No-Frost evaporator)	[Kg]	3.590	3.700
Shipping weight INTEGRATA unit / IN (No-Frost evaporator) / LN low noise	[Kg]	2.600	2.710
Working weigth INTEGRATA unit / IN (No-Frost evaporator) / LN low noise	[Kg]	3.600	3.710

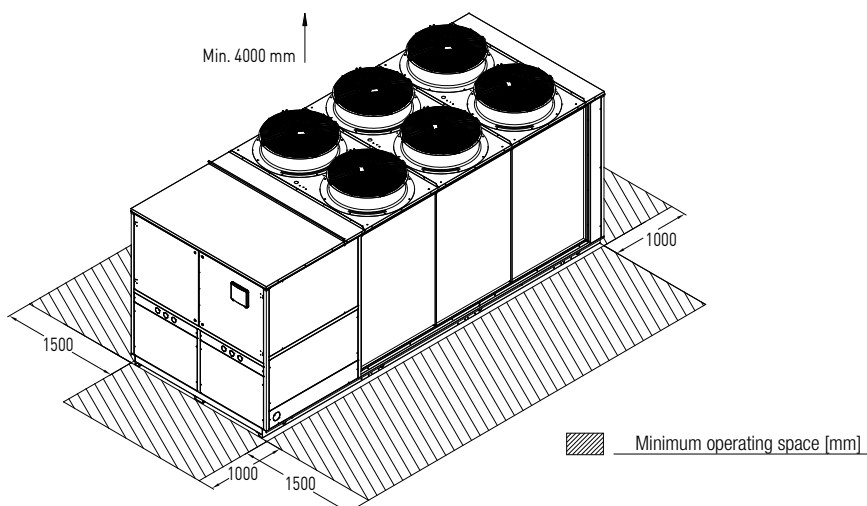

Standard and optional packing

The standard packing foreseen for EKE range consists of heat-shrinkable plastic film that cover the whole unit and protect it from dust, water and other atmospheric agents. Polystyrol corner are also foreseen in order to protect the unit from potential damages caused during transports.

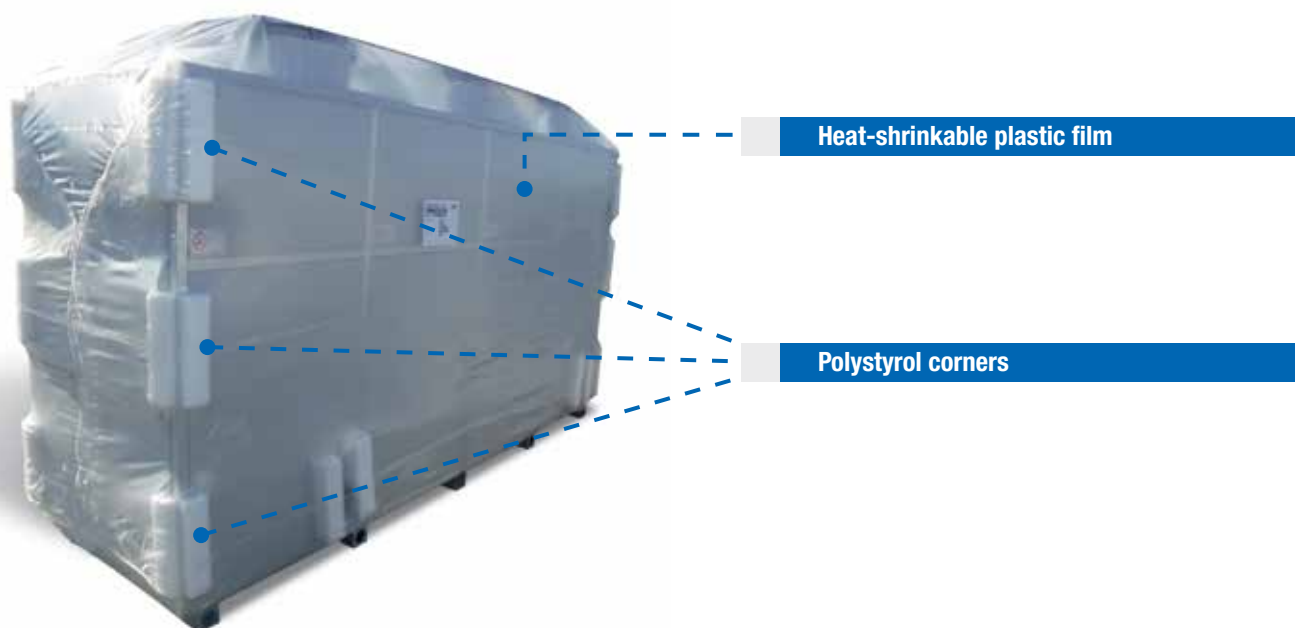

EKE	21 ÷ 51	81 ÷ 151	201 ÷ 252	302 ÷ 402	502 ÷ 702	804 ÷ 1404
-----	---------	----------	-----------	-----------	-----------	------------

Standard packing	●	●	●	●	●	●
Standard packing with wooden base	○	-	-	-	-	-
Wooden cage packing without base	○	○	○	○	○	-

● *standard equipment* ○ *optional* - *not available*

Piping and Instrumentation Diagram for units: 21 ÷ 402

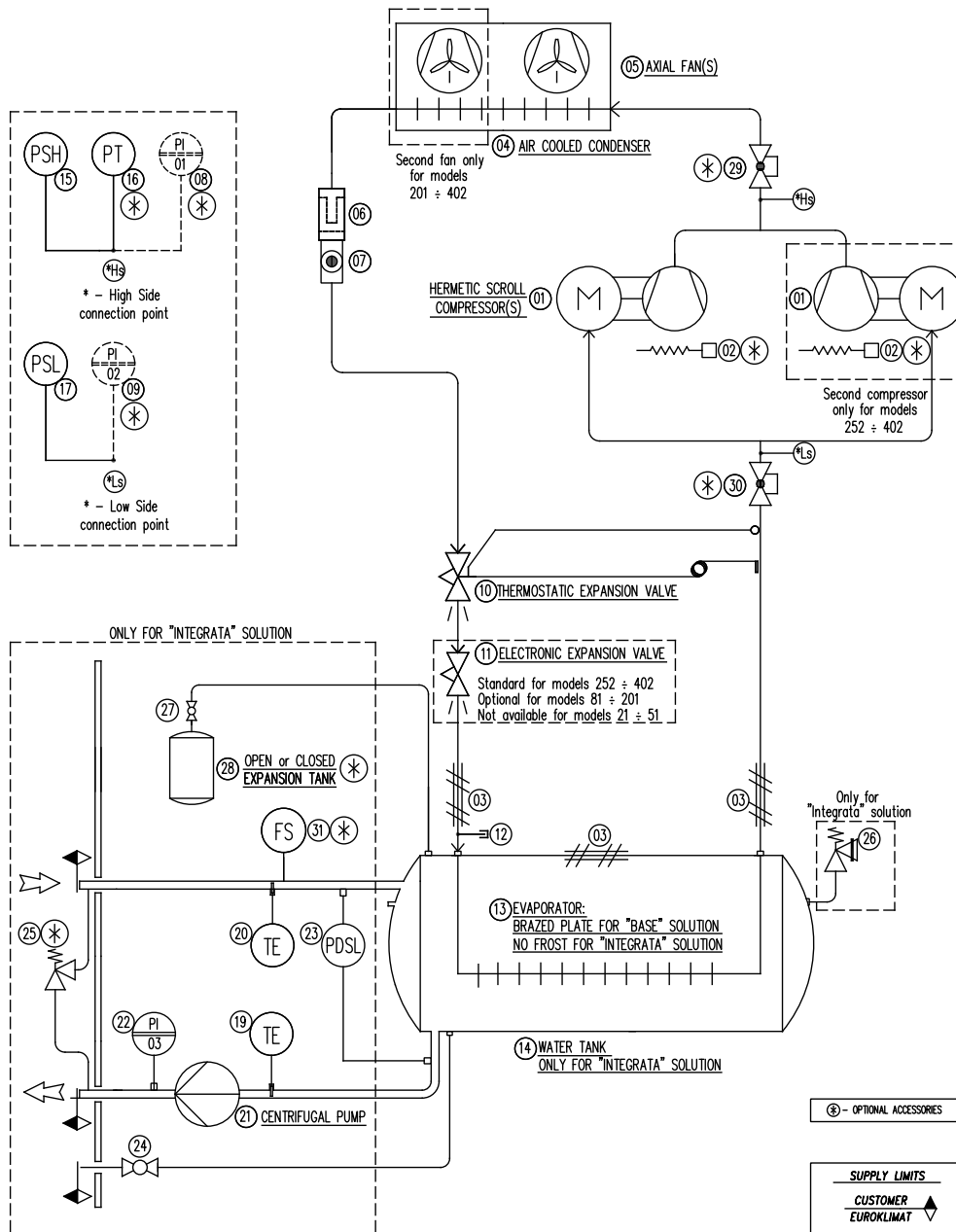

Piping and Instrumentation Diagram for units: 502 ÷ 702

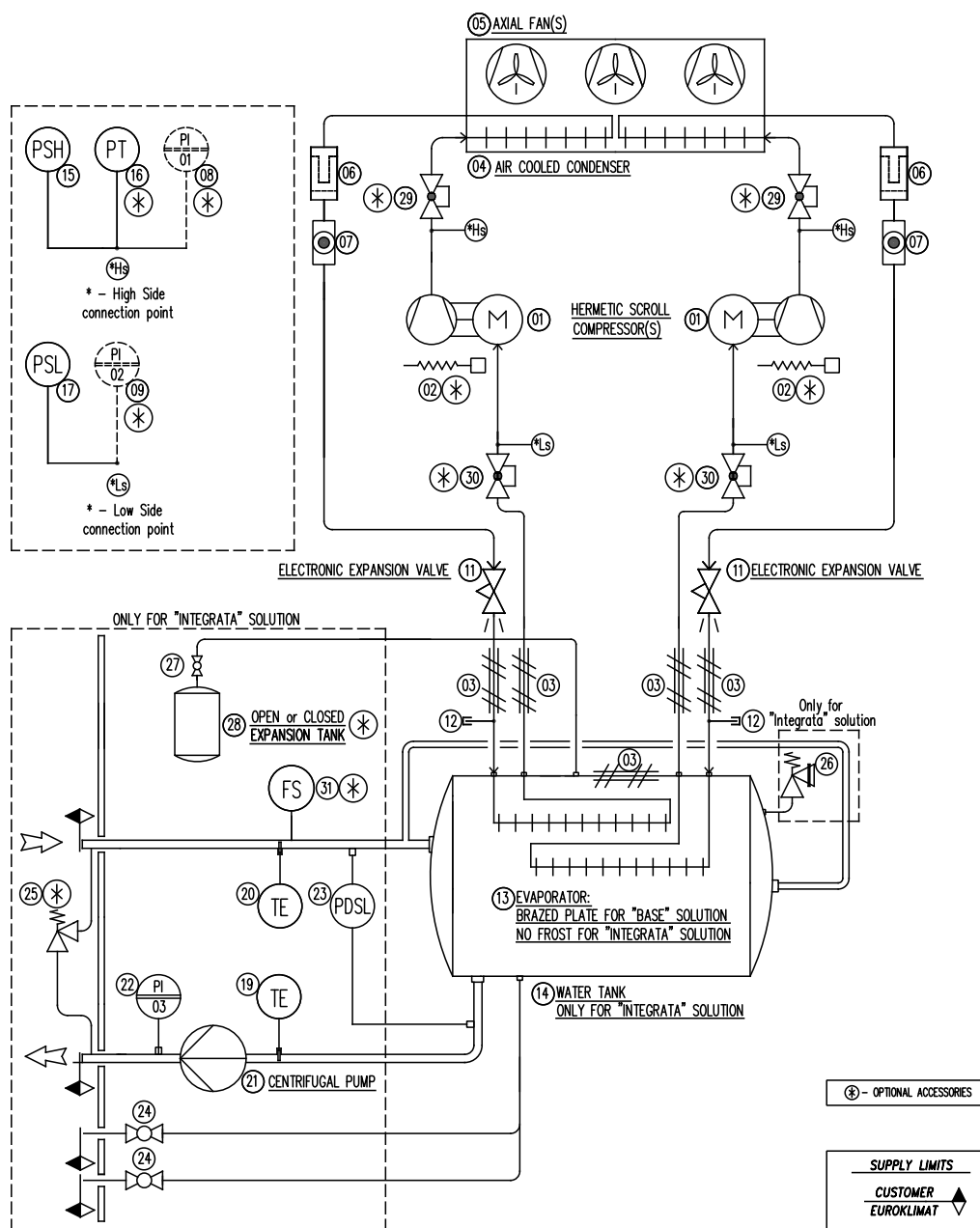

Legend

01	Hermetic scroll compressor	09	Low pressure gauge	17	Low pressure switch	25	Automatic by pass valve
02	Oil crankcase heater	10	Thermostatic expansion valve	18	Pressure safety valve (HP side)	26	Pressure safety valve
03	Insulation	11	Electronic expansion valve	19	Temperature sensor - Evaporator outlet	27	Air exhaust valve
04	Air cooled condenser	12	R410A charging point	20	Temperature sensor - Evaporator inlet	28	Open or Closed expansion tank
05	Axial fan	13	Evaporator	21	Centrifugal pump	29	Compressor discharge valve
06	Dehydrator filter	14	Water tank	22	Water pressure gauge	30	Compressor suction valve
07	Sight glass	15	High pressure switch	23	Differential pressure switch	31	Flow switch - Water circuit
08	High pressure gauge	16	Pressure transducer	24	Drain valve		

Piping and Instrumentation Diagram for units: 804 ÷ 1404

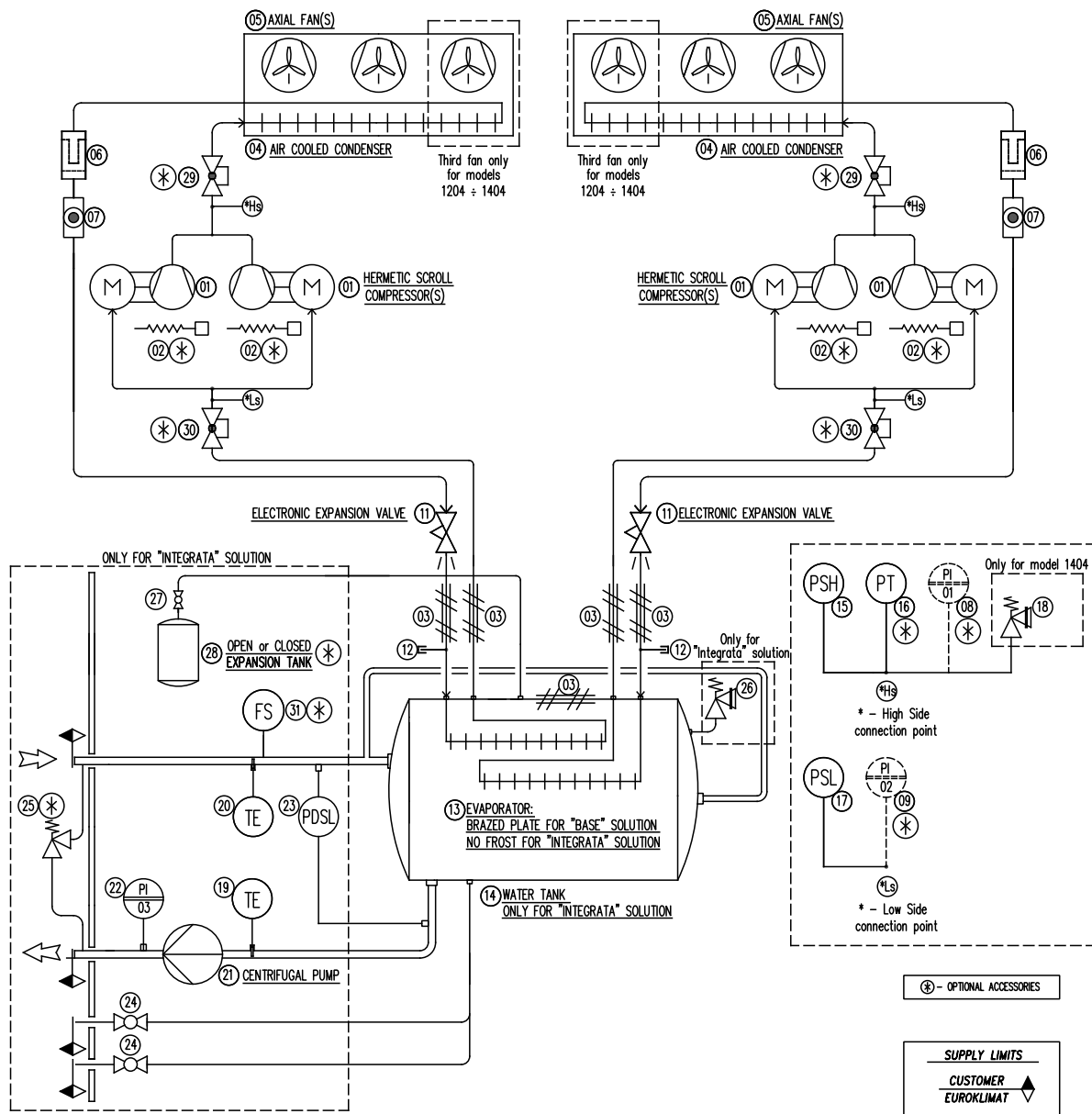

WebService²

What do I receive with my order?

When you order an Euroklimat product, after the order confirmation, you get your user ID and password to access to WebService². With the advent of information technology, there are several possibilities for communication and transmission of information in real-time. Euroklimat wanted to exploit these instruments creating a website, which provides an important support to all customers: WebService².



WebService² - web portal 24/7

The simple and intuitive interface of the site allows you to “browse” quickly and easily reach the information you need. Planned and designed for the specific competences, “webservice” is a web portal that enables customers or support centres to access the detailed documentation for each single machine:

- » order confirmation, waybill and invoice
- » declaration of conformity
- » instructions manual
- » electric diagram
- » construction drawing
- » complete list of spare parts
- » ... and much much more.



The information is consequently always available and up-to-date, also when you are physically at the site of installation.

Thanks to the new features of WebService², it is now possible to check in real time the availability of spare parts for each serial number, simply by accessing the service with your own web credentials.

The “mission” of Euroklimat is always to improve the service offered to customers.





Our plants and quality management

Over 50 years of business

Since we set up business in 1963, the company's head offices have always been in Italy, near Milan. Today, our aim is to be a market leader in chillers with natural refrigerant (propane): by doing this, we are helping the industry to become more efficient, preserving natural resources and protecting the environment.

Organization in Italy

At our Italian plant spread over an area of 6,000 square metres, with a work force of 60 people, Euroklimat designs and produces refrigeration units, heat pumps and precision air conditioners that can be used both in industrial processes and traditional comfort applications.

Infinite quality

Euroklimat firmly believes that Customer Satisfaction is an indispensable factor for success. A priority objective to achieve this result is the constant improvement of our products, services and the relative production processes.

This objective means involving all of the company's resources with planned, systematic activities for Quality; for this reason, our system complies with the international standard UNI EN ISO 9001:2015.

Organization in China

Our plant covers a surface of approximately 100,000 square metres, with over 1,000 people and includes a large test chamber and a sophisticated R&D laboratory, in addition to real production departments, where the performance of the units is measured before being placed on the market.



**COMPANY
WITH QUALITY SYSTEM
CERTIFIED BY DNV GL
= ISO 9001 =**



Factory Italy • Siziano



Factory China • Huangjiang, Dongguan, Guangdong

**EUROKLIMAT SpA**

Factory Italy

Via Liguria, 8
27010 Siziano (PV) ItalyT: +39 038 2610282
E: info@euroklimat.itwww.euroklimat.it**Euroklimat Co., Ltd**

Factory China

Euroklimat Industrial Park,
Huangjiang, Dongguan, Guangdong, ChinaT +86 0769 8366 0888 ext. 8260
E: info@euroklimat.itwww.euroklimat.com.cn**EUROKLIMAT FZCO**

Office Dubai

High Bay Office 24, Dubai Silicon Oasis,UAE
PO Box 28178, Dubai, UAET + 971 4 3423152
E: info@ek-me.comwww.euroklimatme.com