

C	27/11/25	Integrato modello EKE 31	DESCRIZIONE
B	14/10/25	Revisione generale posizione attacchi	
A	02/09/25	Emissione	
Mod.	Data		
		Dis.	Contr.
		AV	Approv.
		GR	
		GR	
		GR	

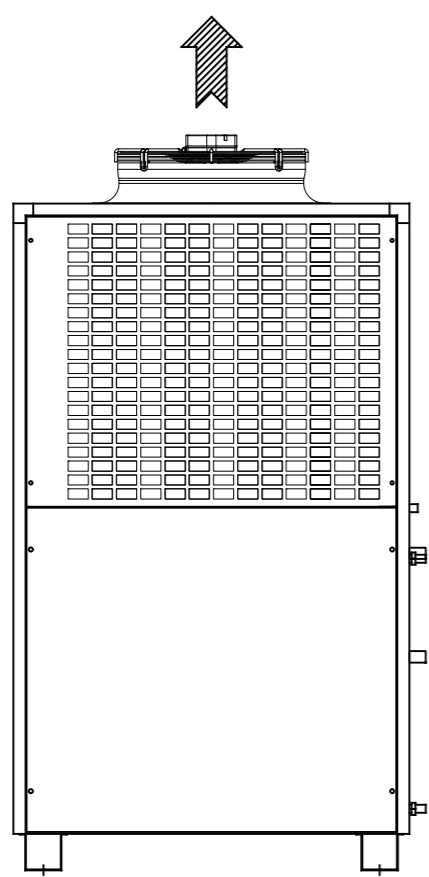

VISTA POSTERIORE
BACK VIEW

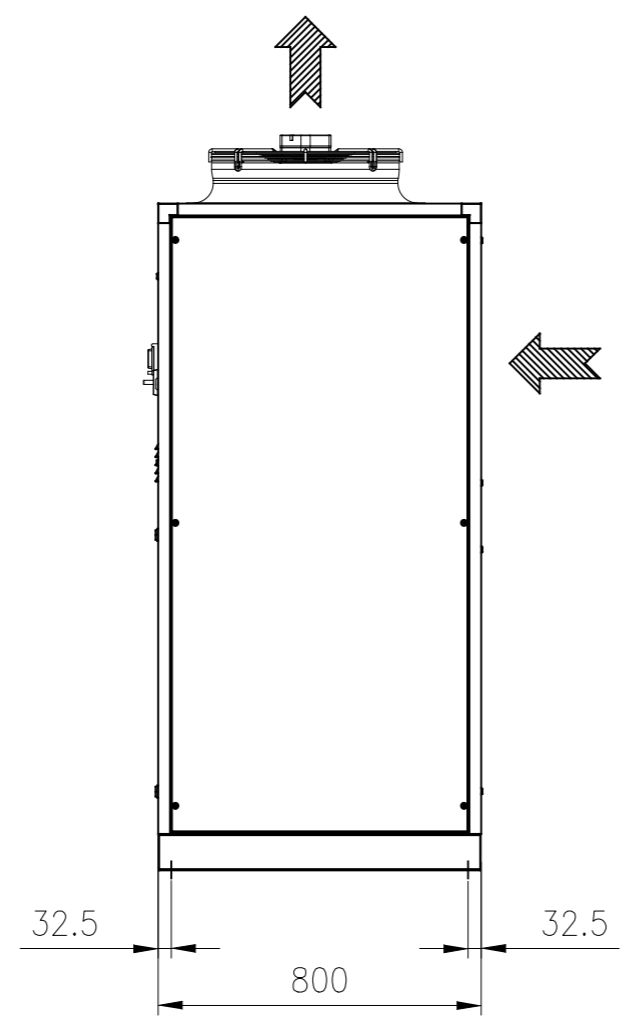

VISTA LATERALE
SIDE VIEW

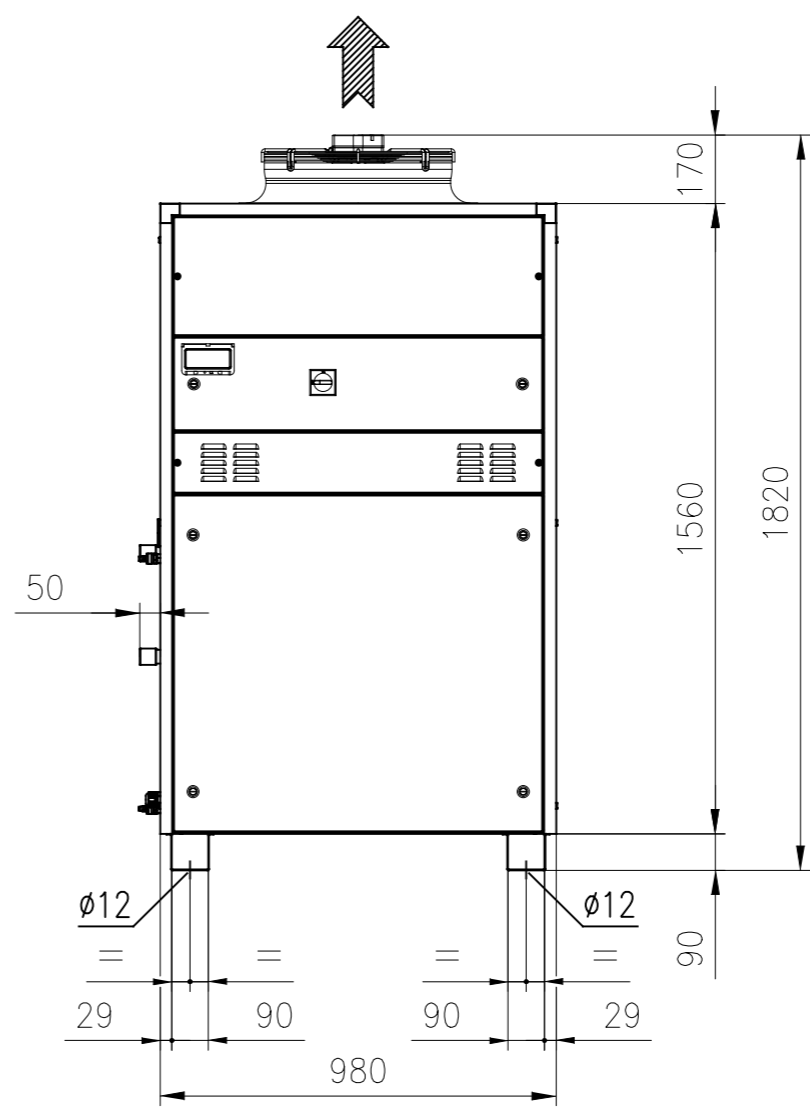

VISTA ANTERIORE
FRONT VIEW

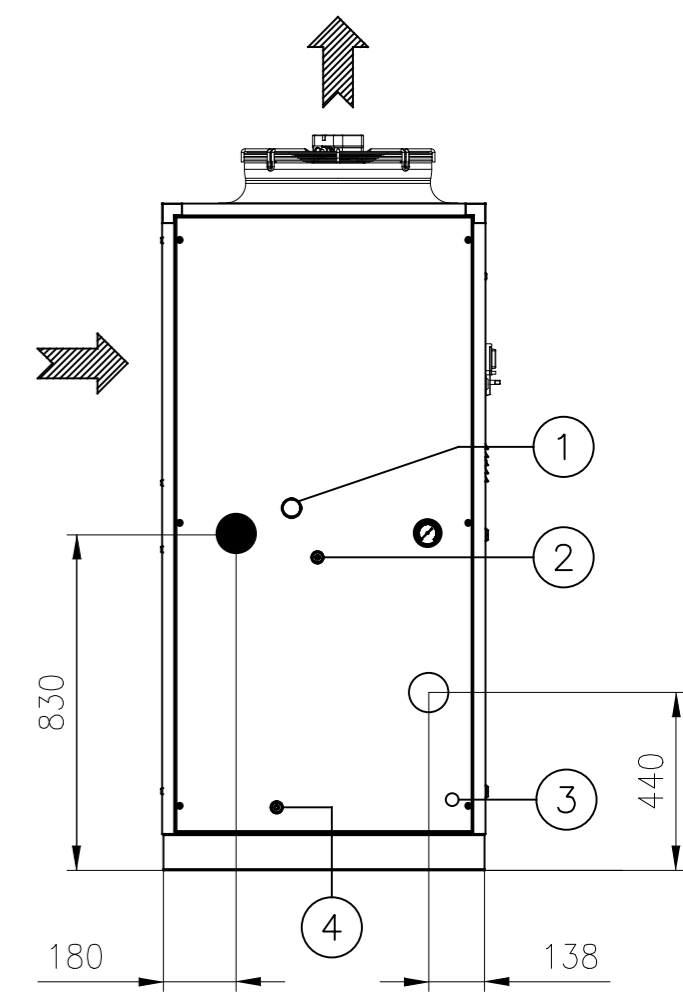

VISTA LATERALE
SIDE VIEW



FLUSSO ARIA AL CONDENSATORE
CONDENSER AIR FLOW



ENTRATA ACQUA – GAS 1”
WATER INLET – BSP 1”

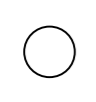

USCITA ACQUA – GAS 1”
WATER OUTLET – BSP 1”

	EKE 31	EKE 51
PESO SPEDIZIONE SHIPPING WEIGHT	Kg. 245	Kg. 260
PESO IN OPERA OPERATING WEIGHT	Kg. 305	Kg. 320

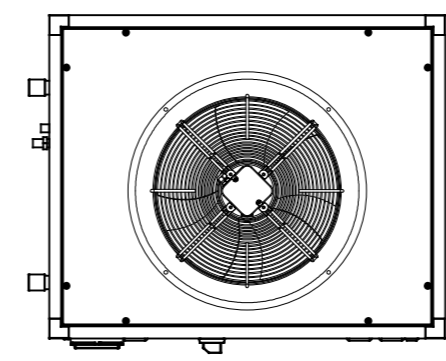

VISTA DALL'ALTO
TOP VIEW

- ① SCARICO CONDENSA
CONDENSATE DISCHARGE
- ② VALVOLA SFOGO ARIA
AIR PURGE VALVE
- ③ ALIMENTAZIONE ELETTRICA
POWER SUPPLY
- ④ CARICO/SCARICO ACQUA
WATER CHARGE/DISCHARGE



EUROKLIMAT. Cooling System Solutions
EUROKLIMAT SPA
Via Liguria, 8 27010 Siziano (PV) Italy
e.: info@euroklimat.it w.: www.euroklimat.it

Scala: / Disegno n° : 15535130/001-C

Dimensionale Serie EKE 31-51 R454B New Gen

Valido per: .