

Ficha técnica producto / Product data sheet

Características / Characteristics	Valor / Value
Tipo y calidad fluido / Fluid type and quality	Aceite / agua / agua+glicol filtrada < 100 µm Filtered oil / water / water+glycol < 100 µm
Caudal recomendado / Recommended flow	10-100 l/min
Conexión hidráulica / Couplings	1"
Presión max. / Maximum pressure	17 bar
Temperaturas de trabajo / Working temperatures	-40 / 60°C
Potencia y consumo corriente / Power and current	120 W / 0,55 A
Conexión eléctrica / Voltage	1-230 V / 50-60 Hz
Velocidad giro / Angular velocity	2800 rpm
Flujo de aire / Air flow	1200 m ³ /h
Nivel sonoro / Sound level	78 db (A)
Protección / Enviromental protection class	IP 54 cl.F
Peso / Weight	10 kg

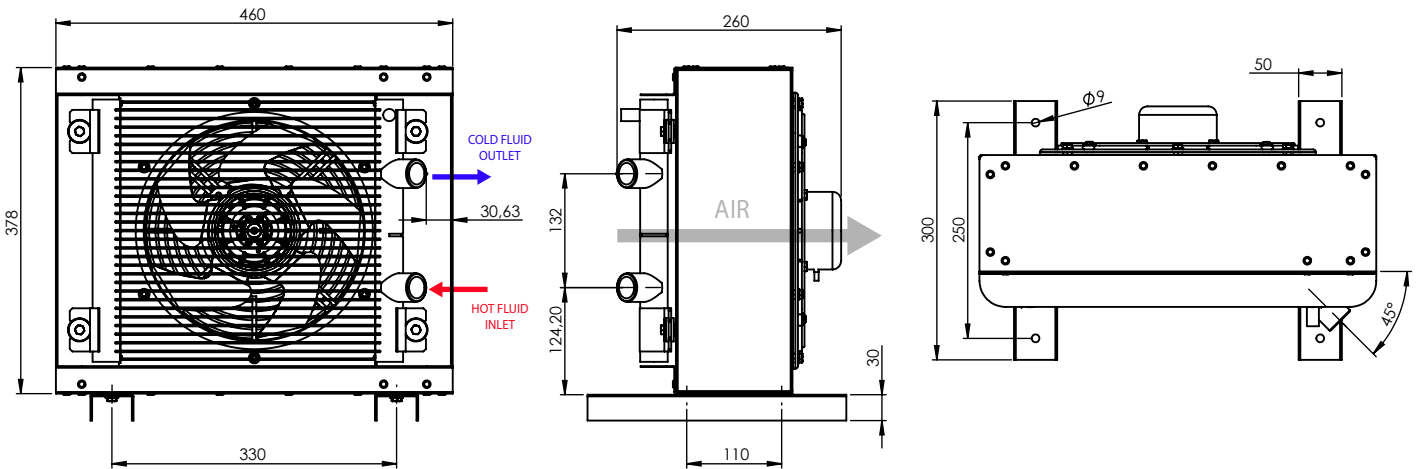

Caida presión fluido frente a caudal / Drop fluid pressure vs flow

Viscosidad / Viscosity (mm ² /s)	Factor corrección K / Conversion factor K
10	0,35
15	0,5
22	0,75
30	1
46	1,4
68	1,9
100	2,5
150	3,5

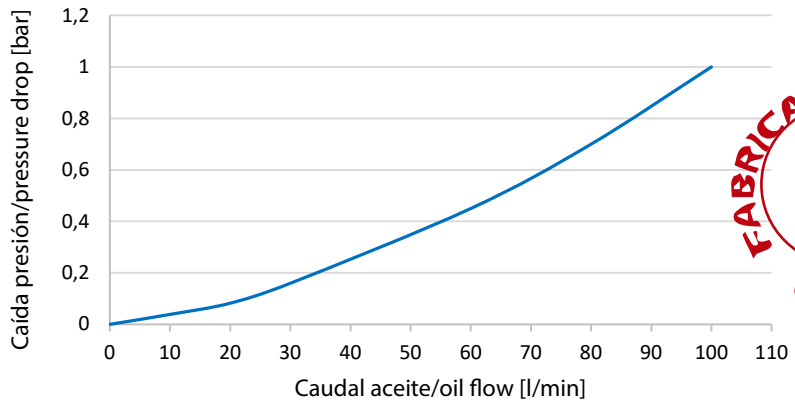

Modos de instalación mecánica / Mechanical installation modes

Modo de instalación 1 usando la bancada / Assembly mode 1 using the bench

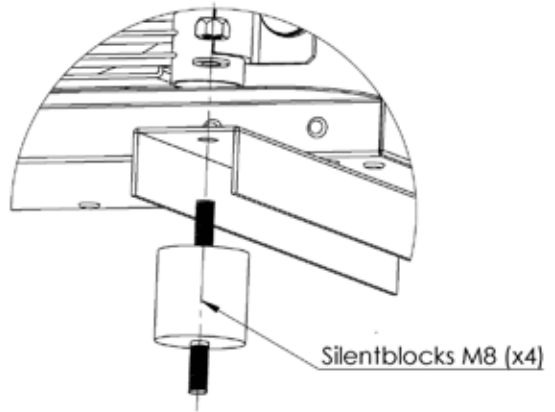
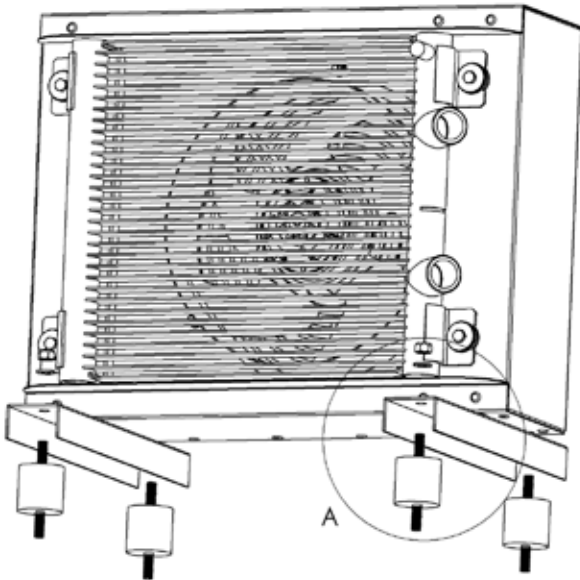

Modo de instalación 2 sin usar la bancada / Assembly mode 2 without using the bench

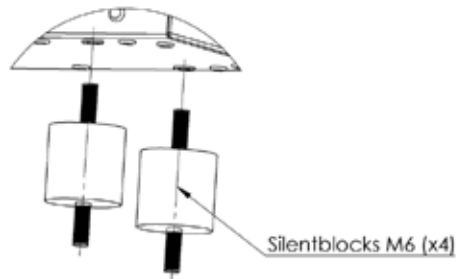
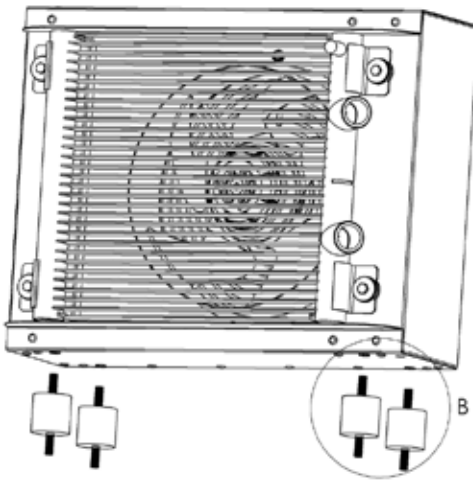

Esquema conexión eléctrica / Electrical connection scheme

