

# AFTERCOOLER ACA-HP 003 - 600

(Air cooled aftercooler)

## DESCRIPTION

Air cooled aftercoolers series ACA-HP have been designed to reduce compressed air temperature in high pressure compressed air systems. High efficiency axial fan forces ambient air over the heat exchangers copper tubes supported by aluminium fins, which provides the necessary cooling effect. The compressed air is cooled down to approximately 10°C above ambient temperature. ACA-HP aftercoolers ensure the maximum performance and protection of all equipment, such refrigeration dryers, adsorption dryers and filters, positioned downstream of this unit.



## APPLICATIONS<sup>(1)</sup>

- Automotive
- Electronics
- Food & Beverage
- Chemical
- Petrochemical
- Plastics
- Paint
- General industrial application

<sup>(1)</sup>ACA-HP aftercoolers can be used in variety of applications. For applications not listed please contact us or your local dealer.

## ADMISSABLE FLUIDS

**Fluid group 2:** non-explosive, non-flammable, non-toxic and non-oxidising media (air, N<sub>2</sub>, He, Ar and mixtures of these gases).

## TECHNICAL SPECIFICATIONS

Max. working pressure	40 barg
Max. operating temperature	120 °C
Max. ambient temperature	45°C
Protection class – junction box	IP54

## MATERIALS

Condenser	Aluminium, copper
Frame	Carbon steel
Screws	Zinc plated carbon steel
Outside protection (frame)	Powder paint coated (Epoxy-polyester base)

**SIZES**

Model	Supported flow <sup>(2)</sup> [Nm <sup>3</sup> /h]	Connection	Power supply [Ph~V-Hz]	Fan diameter [mm]	Fan power rating <sup>(3)</sup> [W]	Cooling air flow [Nm <sup>3</sup> /h]	Dimensions [mm]			Weight [kg]
							A	B	C	
ACA-HP 003	66	G 1"	1~230-50/230-60	∅ 250	40/52	400	884	245	400	20
ACA-HP 007	126	G 1"	1~230-50/230-60	∅ 250	40/52	400	884	245	400	21
ACA-HP 018	294	G 1 1/2"	3~400-50/440-60	∅ 400	130	3800	1014	321	560	31
ACA-HP 030	390	G 2"	3~400-50/440-60	∅ 500	540	7000	1134	321	760	49
ACA-HP 047	522	G 2"	3~400-50/440-60	∅ 500	540	7000	1280	329	760	52
ACA-HP 070	774	G 2"	3~400-50/440-60	∅ 630	Δ620/Y440	8000	1450	490	786	67
ACA-HP 094	990	G 2 1/2"	3~400-50/440-60	∅ 630	Δ620/Y440	8000	1450	490	770	72
ACA-HP 150	1260	DN100	3~400-50/440-60	∅ 800	1470	21000	1630	644	1616	136
ACA-HP 175	1560	DN100	3~400-50/440-60	∅ 800	1470	21000	1630	644	1616	136
ACA-HP 240	1890	DN100	3~400-50/440-60	∅ 800	1470	21000	1630	644	1616	136
ACA-HP 300	2520	DN100	3~400-50/440-60	∅ 800	1470	21000	1863	644	1680	172
ACA-HP 450	3090	DN125	3~400-50/440-60	2x ∅ 800	1470	2x21000	2090	674	2540	222
ACA-HP 600	4500	DN125	3~400-50/440-60	2x ∅ 800	1470	2x21000	2090	704	2540	326

<sup>(2)</sup> Compressed air flow at 7 bar(g) and 20°. Compressed air outlet temperature 10°C higher than ambient air temperature.

<sup>(3)</sup> For 60 Hz 20 % more than stated.

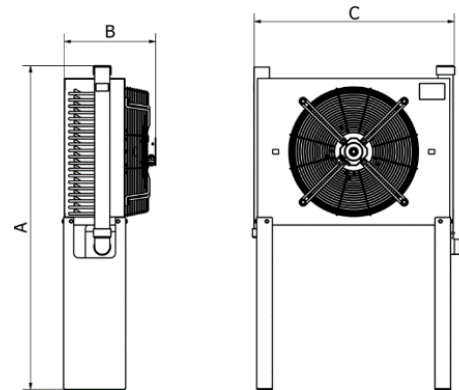

**CORRECTION FACTORS**

To calculate the correct capacity of a given dryer based on actual operating conditions, multiply the nominal flow capacity by the appropriate correction factor(s).

CORRECTED CAPACITY = NOMINAL FLOW CAPACITY x C<sub>OP</sub>

**OPERATING PRESSURE**

[bar]	2	5	7	10	13	16	20	30	40	50
[psi]	29	72	100	145	189	232	290	435	580	725
C <sub>OP</sub>	0,38	0,86	1	1,38	1,75	2,13	2,63	3,88	5,13	6,38