

# ACTIVATED CARBON TOWER - TAC-HP

## DESCRIPTION

TAC-HP activated carbon towers have been developed for separating oil vapours from compressed air<sup>(1)</sup> (dry type separation). TAC-HP series is made from stainless steel. Flow distributors ensure uniform distribution of air flow through activated carbon bed. Oil vapours as well as some other hydrocarbons are separated due to adsorption process. Super fine coalescing filter is required upstream TAC-HP and 1µm dust filter is recommended downstream to intercept activated carbon dust.

## APPLICATIONS<sup>(2)</sup>

- Automotive
- Electronics
- Food & Beverage
- Chemical
- Petrochemical
- Plastics
- Paint
- General industrial application

<sup>(1)</sup>For any other technical gas please contact us or your local dealer

<sup>(2)</sup>HP-TAC filter housing can be used in variety of applications. For applications not listed please contact us or your local dealer.

## ACTIVATED CARBON TOWER RATING ACCORDING TO ISO8573-1

Solid particles	Water	Oil
-	-	0 / 1

## TECHNICAL SPECIFICATION

Operating temperature	1,5 - 50 °C
Operating pressure	50 bar / 100bar / 250bar / 420bar
Differential pressure	Approx. 100mbar
Oil vapour content (nominal) <sup>(3)</sup>	< 0,003 mg/m <sup>3</sup>

<sup>(3)</sup>at inlet concentration < 0,01 mg/m<sup>3</sup>, liquid content should be removed in advance by fine coalescing filtration

## MATERIALS

Housing material	Stainless steel
Fittings, Screws	Carbon steel – zinc plated
Sealing	NBR
Outside protection (frame)	Powder paint coated (Epoxy-polyester base)
Lubricant	Shell cassida grease RLS 2

## SIZES

ADSORBER HOUSING	CONN. SIZE**	FLOW CAPACITY*		DIMENSIONS			ACTIVATED CARBON [kg]	VOLUME [l]	WEIGHT [kg]
		[m <sup>3</sup> /h]	[scfm]	A[mm]	B[mm]	C[mm]			
TAC-HP 050 PN50	G 3/8"	50	29	1200	630	350	1,60	3,2	52
TAC-HP 100 PN50	G 3/8"	100	59	1250	630	350	3,35	6,7	60
TAC-HP 150 PN50	G 3/8"	150	88	1550	630	350	5,20	10,4	68
TAC-HP 250 PN50	G 3/8"	250	147	1700	630	350	8,70	17,4	104
TAC-HP 350 PN50	G 1/2"	350	206	1700	680	450	12,65	25,3	128
TAC-HP 500 PN50	G 1/2"	500	294	1920	680	450	16,20	32,4	164
TAC-HP 650 PN50	G 1/2"	650	383	2250	680	450	22,10	44,2	184
TAC-HP 50 PN100	G 3/8"	50	29	1250	630	350	0,80	1,6	50
TAC-HP 100 PN100	G 3/8"	100	59	1350	630	350	1,80	3,6	68
TAC-HP 150 PN100	G 3/8"	150	88	1650	630	350	2,55	5,1	80
TAC-HP 250 PN100	G 3/8"	250	147	1550	630	350	4,15	8,3	84
TAC-HP 350 PN100	G 1/2"	350	206	1460	630	350	5,90	11,8	108
TAC-HP 500 PN100	G 1/2"	500	294	1700	630	350	8,40	16,8	116
TAC-HP 650 PN100	G 1/2"	650	383	1800	680	450	11	22	152
TAC-HP 800 PN100	G 1/2"	800	471	1850	680	450	14	28	192
TAC-HP 50 PN250	G 3/8"	50	29	1000	630	350	0,40	0,8	38
TAC-HP 100 PN250	G 3/8"	100	59	1360	630	350	0,80	1,6	54
TAC-HP 150 PN250	G 3/8"	150	88	1600	630	350	1,10	2,2	58
TAC-HP 250 PN250	G 3/8"	250	147	1500	630	350	1,80	3,6	72
TAC-HP 350 PN250	G 1/2"	350	206	1500	630	350	2,60	5,2	120
TAC-HP 500 PN250	G 1/2"	500	294	1500	630	350	3,50	7	112
TAC-HP 650 PN250	G 1/2"	650	383	1500	680	450	4,65	9,3	160
TAC-HP 800 PN250	G 1/2"	800	471	1550	680	450	5,85	11,7	184
TAC-HP 1000 PN250	G 1/2"	1000	589	1600	680	450	7,25	14,5	232
TAC-HP 1200 PN250	G 1/2"	1200	706	1550	680	450	8,80	17,6	248
TAC-HP 1400 PN250	G 1/2"	1400	824	1650	680	450	10,75	21,5	260
TAC-HP 100 PN420	G 3/8"	100	59	1120	630	350	0,50	1	48
TAC-HP 150 PN420	G 3/8"	150	88	1360	630	350	0,80	1,6	54
TAC-HP 250 PN420	G 3/8"	250	147	1450	630	350	1,25	2,5	76
TAC-HP 350 PN420	G 1/2"	350	206	1350	630	350	1,65	3,3	108
TAC-HP 500 PN420	G 1/2"	500	294	1380	630	350	2,25	4,5	124
TAC-HP 650 PN420	G 1/2"	650	683	1450	630	350	3,05	6,1	176
TAC-HP 800 PN420	G 1/2"	800	471	1230	630	350	3,70	7,4	170
TAC-HP 1000 PN420	G 1/2"	1000	589	1450	630	350	5,00	10	240
TAC-HP 1200 PN420	G 1/2"	1200	706	1450	680	450	5,70	11,4	340
TAC-HP 1400 PN420	G 1/2"	1400	824	1500	680	450	7,15	14,3	320
TAC-HP 1600 PN420	G 1/2"	1600	942	1450	680	450	7,65	15,3	480

\* Refers to 1bar(a) and 20°C, at nominal operating pressure and inlet temperature 20°C

\*\*Standard connections: inlet top, outlet bottom

## PRESSURE EQUIPMENT DIRECTIVE PED 2016/68/EU (Fluid group 2)

Category 2, Module H
Category 3, Module H

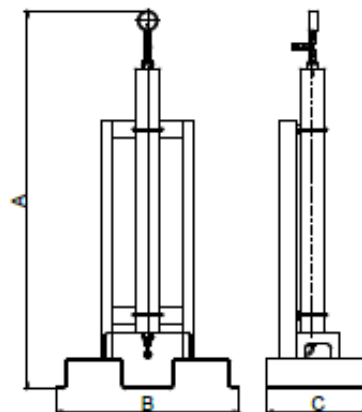

### CORRECTION FACTORS

To calculate the correct capacity of a given tower based on actual operating conditions, multiply the nominal flow capacity by the appropriate correction factor(s).

$$\text{CORRECTED CAPACITY} = \text{NOMINAL FLOW CAPACITY} \times C_{OP} \times C_{OT}$$

#### OPERATING PRESSURE (TAC-HP PN50)

[bar]	25	30	35	40	45	50
[psi]	363	435	508	580	653	725
C <sub>OP</sub>	0,51	0,61	0,71	0,81	0,9	1

#### OPERATING PRESSURE (TAC-HP PN100)

[bar]	50	60	70	80	90	100
[psi]	725	870	1015	1160	1305	1450
C <sub>OP</sub>	0,5	0,6	0,7	0,8	0,9	1

#### OPERATING PRESSURE (TAC-HP PN250)

[bar]	110	130	160	190	220	250
[psi]	1595	1885	2320	2755	3190	3625
C <sub>OP</sub>	0,44	0,52	0,64	0,76	0,88	1

#### OPERATING PRESSURE (TAC-HP PN420)

[bar]	250	275	300	325	350	375	400	420
[psi]	3625	3990	4350	4715	5075	5440	5800	6091
C <sub>OP</sub>	0,59	0,65	0,71	0,77	0,83	0,89	0,95	1

#### OPERATING TEMPERATURE

[°C]	20	25	30	35	40	45	50
C <sub>OT</sub>	1	0,98	0,97	0,92	0,86	0,75	0,6

### MAINTENANCE

Replace activated carbon every 12 months or sooner if required. Check residual oil content with oil indicator monthly.